

Current Sense Resistors



The need to measure the flow of current in electronic systems is becoming increasingly widespread. Reasons for this include the growth of battery-powered portable products, increasing concern to minimise energy usage, and the spread of electrically actuated systems in cars.

In this context, measuring a current means converting it to a voltage, which may then be compared with a threshold, digitised or otherwise processed by a current sense circuit. There are several solutions for doing this, including current transformers, hall-effect sensors and magnetoresistive sensors. However, the simplest and, in many cases, lowest cost method is to employ Ohm's law in the form of a current sense resistor.

There are two problems traditionally associated with using a resistor to measure current. The first is the power dissipation at high currents - even a $1\text{m}\Omega$ resistor dissipates 10W at 100A . The second is the lack of electrical isolation between the high current path and the sense circuit. Advances in interface circuits, which can offer both high sensitivity and isolation, can tackle both of these problems.

TT electronics Welywn / IRC offers a large range of standard resistive current sense products. In addition to this, TT electronics Welywn / IRC has many years of experience in adapting or designing components to meet the requirements of specific current sense applications.

- High precision, low value axial and chip resistors
- High power, 2- and 4- terminal current shunts
- Custom design service



Subsidiaries of TT electronics plc



Excellence in Technology

Low-Current Applications

Battery Charger

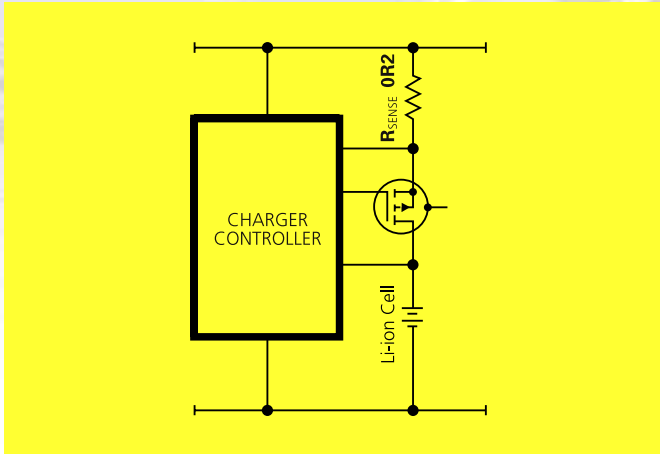

Portable, battery powered equipment is a rapidly expanding product area. The drive for more features and less frequent re-charging has led to lithium-ion becoming the preferred technology, with its superior energy density. The task of charging a lithium-ion battery is, however, more demanding than for earlier types. This has given rise to the development of charger controller IC's, which regulate the current and voltage within the tight limits required. A typical charging current is 500mA, so a 200mΩ resistor will give 100mV signal with negligible power dissipation. An LR1206-0R2, available to 1%, is a suitable choice.

Hot-Swap Controller

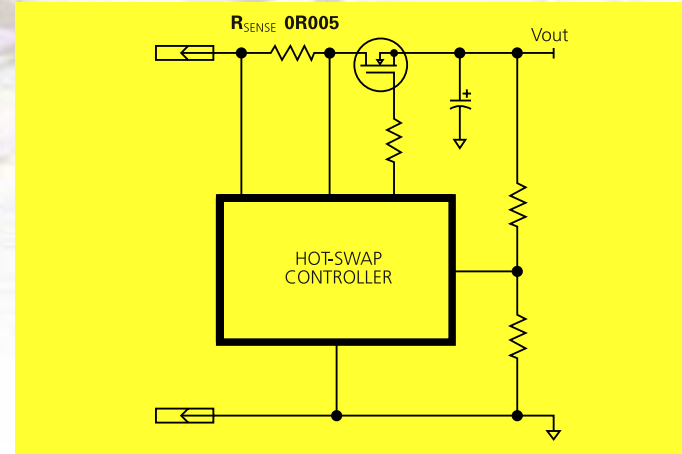

Microprocessor-based boards require power supply rails of high integrity, even under extreme conditions such as removal from and insertion into a live backplane. This may be achieved using a hot-swap controller IC, which regulates the ramp-up of the supply rail on the plug-in card and protects against accidental shorts. This calls for sensing of the current, which may be several amps, depending on the requirements of the plug-in module. For example, a 5A current limit with a 5mΩ resistor gives a 25mV trip level and dissipates up to 125mW. An LR2010-0R005 is ideal here, provided 5% tolerance and >100ppm/°C TCR is acceptable. For applications requiring a tolerance of 1% and TCR of 100ppm/°C extending to values below 50mΩ, the four-terminal Kelvin flip-chip LRK offers a solution.

Low Value Flat Chip Resistors LR Series

- Resistance values down to 0.003 ohms
- Leach resistant solder plated copper wrap around termination
- Low inductance - less than 0.2nH



		LR1206	LR2010	LR2512	LRF3W	LRK2512
Power rating at 70°C	Watts	0.5	1.0	1.5 2.0	3.0	2.0
Resistance range	Ohms	0R003 - -10R			0R003 - 0R1	
Tolerance	%	<0R01 : 5% ≥0R01 : 1,2,5%	1, 2, 5%			
Number of terminals		2	2	2	2	4
Dielectric withstand	Volts	200	200	200	200	200
TCR	ppm/°C	≥0R05 : 100	≥0R05 : 100	≥0R05 : 100	≥0R01 : 100	≥0R01 : 100
Temperature rise at rated power	°C	40	80	90	100	70
Total pad & trace area for rated power at 70°C	mm ²	30	30	100 300	300	300
Nominal dimensions L x W	mm	3.20 x 1.63	5.23 x 2.64	6.50 x 3.25	3.25 x 6.50	6.50 x 3.25
Termination style		≤0R025 Flip-chip, >0R025 Normal			Flip-chip	

Medium Current Applications

One of the most cost sensitive areas for the application of current sense resistors is in power supply modules for the telecoms and IT sector. The currents involved may be higher than can be handled by a chip resistor, but high frequency performance is still important. Low inductance metal element resistors are the ideal solution here.

The circuit below shows one example of a power supply application. It is a linear regulator with current foldback limiting. As the foldback limit is reached, the voltage across R_{SENSE} switches T_2 on, which diverts the base current of T_1 . This overrides the voltage regulation, and the circuit operates in constant current mode.

Power Supply Current Limiting

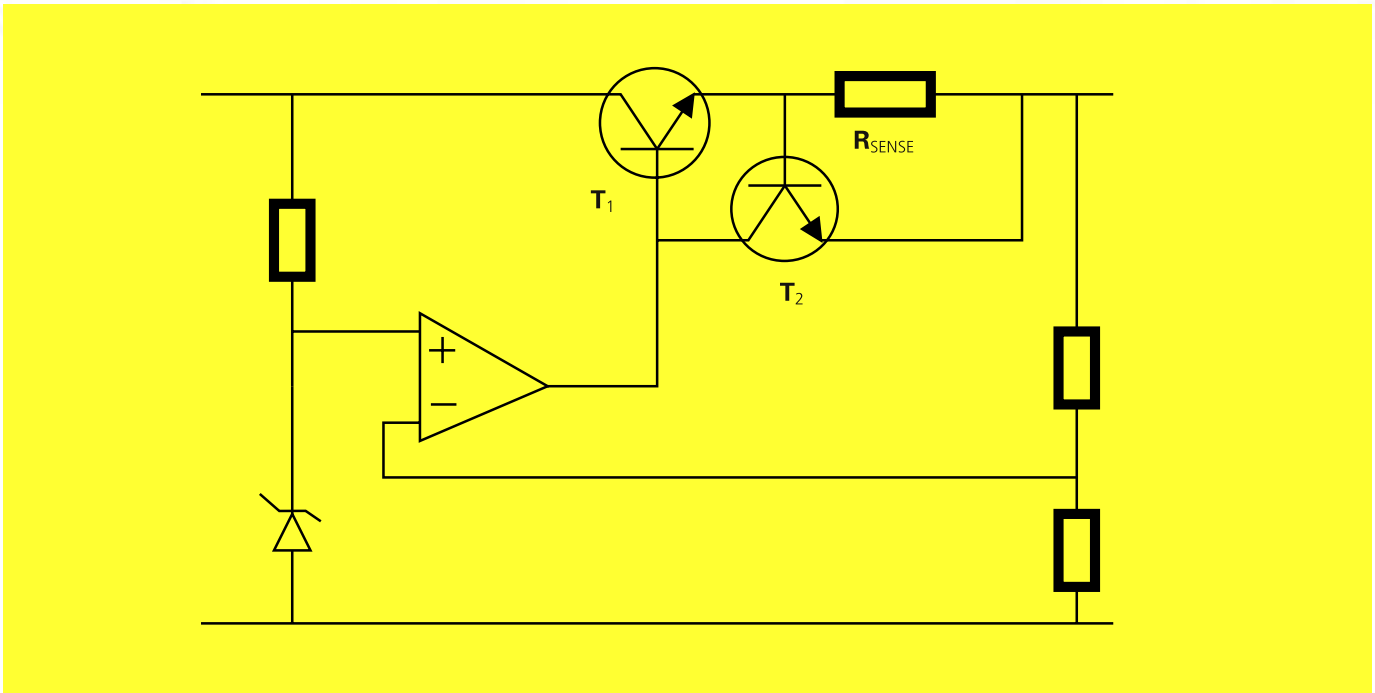

A low cost solution for power supply applications is the OLV series. This is a pluggable metal element resistor with a pitch between 5 and 20mm, and a maximum height of 25mm.

It is rugged, has low inductance and is also suitable in many automotive and industrial applications for current sensing to around 20A.

Open Low Value Sense Resistors OLV Series

- Values down to 5mOhms
- Low inductance
- Designed to individual customer specifications



		OLV-1	OLV-3	OLV-5
Power rating at 25°C	Watts	1	3	5
Resistance range *	mΩ	5, 10, 15, 20	5, 10, 15, 20	10, 15, 20
TCR	ppm/°C	400	350	300
Resistance tolerance	%		5	
Ambient temperature range	°C		-55 to 155	

* Other values available on request.

High Current Applications

The availability of extremely low value sense resistors combined with opto-isolated amplifiers now presents a real alternative to using expensive Hall-effect sensors in the sub-60A range. This is of particular importance in the area of motor control, where isolation from the mains supply is essential. Opto-isolated

resistive current sensing can also give benefits over Hall-effect sensors in terms of temperature stability, linearity and, with careful layout design, common mode rejection.

An example of such a circuit is shown below.

Motor Phase Current Sense

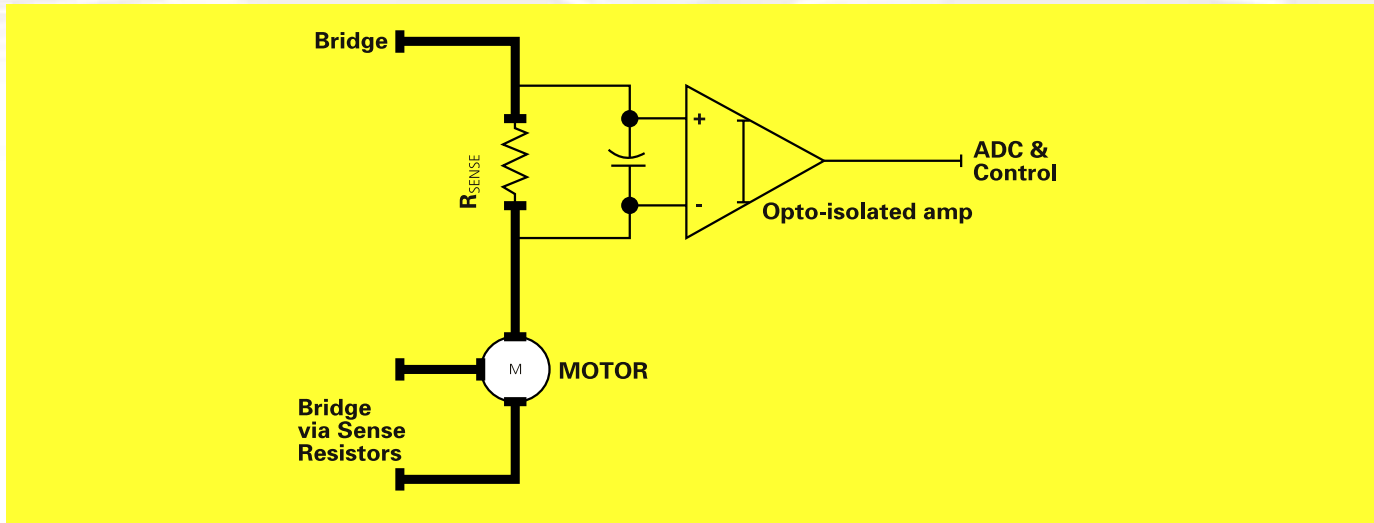

The important attributes in this case are the availability of values below 10mΩ, up to 5W power rating with good surge withstand ability and low inductance. The ideal choice for RMS phase currents up to about 20A is the OAR series, which is a pluggable, formed tape element resistor available in 1, 3 and 5W ratings. The 1W type is also available in surface mountable

form, designated OARS. For RMS phase currents up to 55A, the four-terminal CSL is more suitable. Its rating is also 5W, but values extend down to 0.25mΩ at 1% tolerance. The Kelvin configuration with only the terminals plated gives this device the same TCR as the resistance alloy itself, which is 30ppm/°C.

Open Air Sense Resistors OAR Series

- Flexible leads for thermal expansion
- Resistance wire TCR +/- 20ppm / °C
- Tolerance down to 1%
- Inductance less than 10nH



		OAR-1	OAR-3	OAR-5	OARS-1	CSL-5
Power rating	Watts	1	3	5	1	5
Rated temperature	°C	85	85	85	85	70
Resistance range	mΩ	5 - 100	5 - 100	5 - 50	3 - 50	0.25 - 2.5
Tolerance	%	1, 5	1, 5	1, 5	1, 5	1
TCR	ppm/°C	Value dependent				30
Inductance	nH	<10	<10	<10	<10	<10
Number of terminals		2	2	2	2	4
Mounting		Through-hole	Through-hole	Through-hole	SMD	Through-hole
Max dimensions L x H	mm	11.43 x 5.08	15.24 x 25.4	20.32 x 25.4	11.18 x 3.05	21.9 x 10.8



Designing with Current Sense Resistors

1. Value

Determine the minimum suitable resistance value. This is the lowest value of peak sense voltage consistent with an acceptable signal to noise ratio, divided by the peak current to be measured.

2. Rating

Calculate the power dissipation under operating conditions ($I_{RMS}^2 \cdot R$). Allowing for transient or fault conditions and high ambient temperature if applicable, select the required power rating. For many current sense products, only the maximum temperature of the solder joints limits the power rating. Power rating is thus a function of the PCB layout design as well as of component selection (see point 4.).

3. Tolerance & TCR

Establish the accuracy needed in terms of a tolerance on the value and of sensitivity to temperature. The latter factor is quoted as Temperature Coefficient of Resistance (TCR), defined as the value change in parts per million for a 1°C temperature rise. It is generally higher for low value resistors because the metallic leads or terminations, which have a very high TCR, make up a significant part of the total resistance value.

To achieve acceptable accuracy it is normally necessary to make four-terminal (Kelvin) connections to the resistor. This means connecting the current carrying tracks and the voltage sense tracks directly to the component pads. Even when this is done, there is still some pad area and solder in series with the resistor, which may compromise the actual tolerance and TCR of the soldered part. For very high accuracy or very low values, a four-terminal resistor type should be chosen.

4. Layout

Care must be taken when laying out a PCB if the stated performance of a sense resistor is to be achieved. The current-carrying tracks should be as wide as possible, using multiple layers connected by many vias near the component pad. This also improves the heatsinking of the joints.

The best way to make four-terminal connections to a two-terminal through-hole resistor is to use different sides of the PCB for the current and voltage connections. Failing this, current and voltage tracks should connect to opposite sides of the component pad.

In order to avoid interference from stray magnetic fields, the loop area contained by the sense resistor, the voltage sense tracks and the sense circuit input should be minimised. This means keeping the sense circuitry as close as possible to the sense resistor and running the voltage sense tracks close to each other.

5. Other Factors

Where transient or AC currents involving high frequencies are to be sensed, the self-inductance of the resistor must be minimised. Wirewound or spiralled film parts should be avoided, in favour of bulk metal or low value chips. For example, the LR series chip resistors have inductance values below 200pH.

When using a metallic element shunt with high heat dissipation and low sense voltage, consideration may need to be given to thermoelectric voltages. The junction between a metallic resistance element and metal terminations acts as a thermocouple, generating a voltage proportional to the temperature difference across it. A leaded metallic element sense resistor is therefore like two thermocouples back to back. This means that, if the temperature differences across both junctions are equal, the error voltage is cancelled out. This is achieved by making the design thermally symmetrical, that is, by presenting both terminals with similar heatsinking and by keeping any other heat sources thermally distant.

Current Sense Resistor selection

MAX CURRENT ¹ (A)	TOL ² (%)	TYPE	DESCRIPTION	MAX RATING (W)	AT (°C)	VALUE RANGE (mOhms)	SMD	KELVIN
0.3	0.05	RC	Metal film, epoxy coat	1	70	1000 - HIGH		
1.2	0.1	RCP	Metal film, epoxy coat	1.5	70	1000 - HIGH		
9	1	2504	Metal film, cement coat	2	25	25 - 1000		
15	5	LR(F)	Thick film chip (flip-chip)	2	70	3 - 1000	Yes	
15	1	LRK	Thick film chip	2	70	3 - 100	Yes	Yes
17	5	WSM	Wirewound, molded case	3	70	10 - HIGH	Yes	
17	1	W31	Wirewound, cement coat	3	25	10 - HIGH		
17	1	CSM	Wirewound, cement coat	3	25	10 - HIGH	Yes	
18	1	OARS	Formed tape	1	85	3 - 50	Yes	
20	1	WSML	Wirewound, molded case	2	70	5 - HIGH	Yes	
24	5	OLV	Formed wire	5	25	5 - 20		
31	1	PWRL	Wirewound, ceramic case	10	25	10 - 180		
32	1	OAR	Formed tape, leaded	5	85	5 - 100		
32	1	LOB	Metal element, molded case	5	25	5 - 100		
38	1	PLO	Wirewound, ceramic case	15	25	5 - 180		
38	1	4LPW	Wirewound, ceramic case	15	25	5 - 1000		Yes
55	1	CSL	Metal element	5	70	0.25 - 2.5		Yes
57	10	WH	Wirewound, Al case, h/s mount	50	25	10 - HIGH		

Note 1: Max Current is the approximate upper limit of the current range which may be measured using the lowest value and highest power rating of the given resistor type.

Note 2: Tol is a typical current to voltage conversion error for the given resistor type. It is not necessarily achievable at the low value needed to measure the Max Current.

Full data sheets for all these products may be found on our website.

In addition to offering standard components, TT electronics Welwyn / IRC has experience of developing custom current sense solutions up to hundreds of Amps. Our design service is available to adapt or develop products to meet your specific needs.

Note: Circuit diagrams shown for example only.

TT electronics Welwyn Components Ltd. and IRC Inc. both have over 60 years experience in designing and manufacturing resistive components.

Welwyn Components Limited

Welwyn Electronics Park, Bedlington
Northumberland NE22 7AA, UK

Telephone: +44 (0) 1670 822181
Facsimile: +44 (0) 1670 829465
Email: info@welwyn-tt.com

Website: www.welwyn-tt.com

IRC Inc. (AFD)

4222 South Staples Street
Corpus Christi, Texas 78411, USA

Telephone: +1 361 992 7900
Facsimile: +1 361 992 3377
Email: ircafd@irctt.com

Website: www.irctt.com

