

# Resistors for Circuit Protection

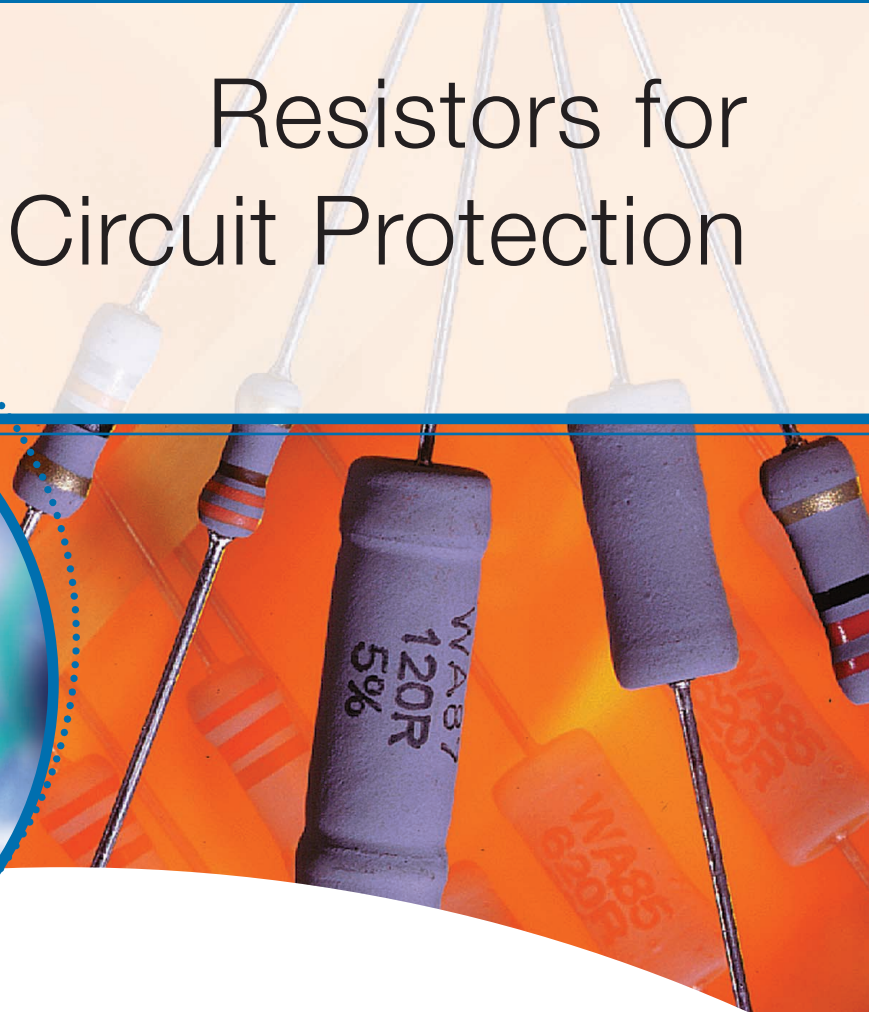

Today's electronic circuits need reliable protection to operate amidst the potential hazards of inrush currents, high voltage surges and other overload conditions. That's why Welwyn resistors have kept circuits safe for more than 50 years, and why Welwyn continue to offer the industry's most comprehensive range of circuit protection resistors.

In addition to offering standard components, Welwyn has worked closely with designers to custom build resistors that are capable of handling high energy pulses and impulses. These components may also be designed to fuse, if required, in a controlled and safe manner under fault conditions.

This unique performance is made possible by:

- Selecting the optimum resistor technology necessary to best match the performance requirements.
- Utilising a specially designed coating system formulated to aid fusing under fault conditions – Fuse Aid.
- Utilising a flameproof protection system to eliminate flame during fusing – Flame Brake.
- Power ratings from 0.25W to 14W; resistance values from 0.01Ω to 10MΩ.

Whether you're designing circuit protection for telecommunications, computers, consumer electronics or office equipment, Welwyn has the right resistor for your application.

**Resistor selected / designed to customer specifications**

**Available technologies include:**

- Metal Film
- Metal Oxide
- Wirewound
- Surface Mount



Subsidiaries of TT electronics plc



**Excellence in Technology**

# 1. RCD Test Resistors

One specialist application for protection resistors is in RCD (Residual Current Device) or GFD (Ground Fault Detector) protection circuits, where these resistors form part of the test circuit as shown in the diagram.

In normal operation, if the RCD detects a current imbalance it will trip a relay causing an open circuit. The purpose of the test circuit is to create this imbalance and cause the relay to operate.

The resistor performs two functions in the test circuit; firstly it creates the load to produce the current imbalance. Secondly the resistor must withstand the initial current, to allow the relay to operate, but then if the relay fails to open the circuit after a given time the resistor must fuse safely.

Typically the relay will operate in 30 to 40 milliseconds. If it fails to do so the Welwyn resistor will fuse safely in 450ms to 2 seconds. The value of this resistor will depend upon the required characteristics of the circuit.

Pulse withstanding capability is typically 4000 volts with a 1.2/50-microsecond waveshape and the resistor can absorb up to 50 joules depending upon the value.

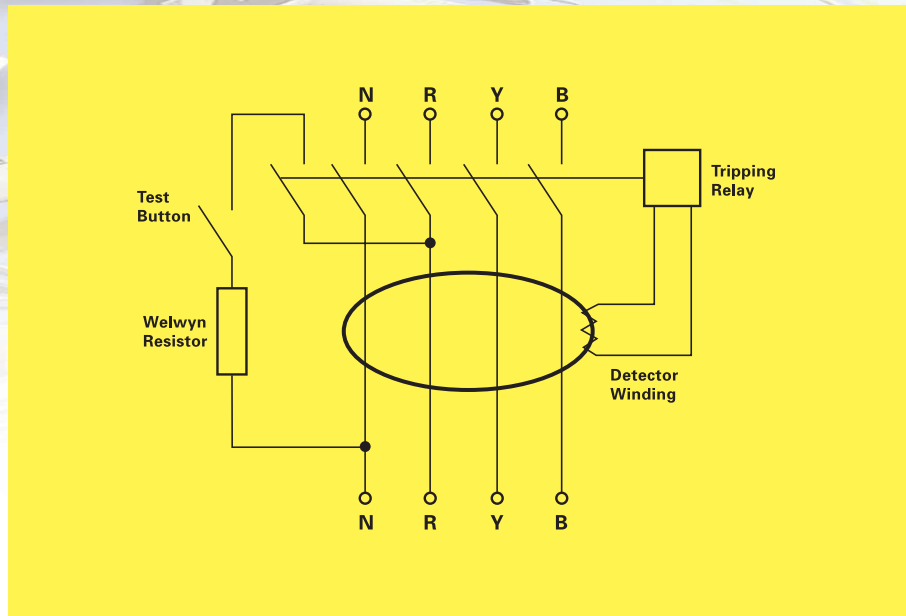

The resistor will fuse safely with 330 watts applied.

The MO-S series of metal oxide resistors has proved very effective in this application, due to their energy handling capabilities and overload withstand ability. Special versions of the MO-S series have also been produced, as detailed in the

example above, which incorporate fusing capabilities to provide fail safe protection. Other designs of RCD's have used Surface Mounted Chip (LR/CR series) resistors in parts of the control circuit.

These 'electronic' versions are usually found in industrial RCD's and in domestic units outside the United Kingdom.

## Power Metal Oxide Film Resistors

MO-S Series

- Small size for power rating
- Can replace carbon composition in many pulse handling applications
- Flameproof protection



### Electrical Data

		MO1/2S	MO1S	MO2S	MO3S	MO4S	MO5S
Power rating at 70°C	watts	0.5	1.0	2.0	3.0	4.0	5.0
Resistance range	ohms	10R - 50K		10R - 100K		10R - 10K	10R - 100K
Limiting element voltage	volts	250		350		500	
TCR	ppm/°C			350			
Isolation tolerance	volts	350		500		700	
Resistance tolerance	%			5, 10			
Standard values				E24 preferred			
Thermal impedance	°C/watt	140	110	80	60	44	35
Ambient temperature range	°C			-55 to +155			

## 2. Inrush Current

Despite technological advances one problem that has never been fully resolved is that of 'inrush' current. This phenomenon, caused by initial capacitor charging surges and/or transformer magnetising currents can subject the input circuitry of equipment to currents many times higher than under normal operating conditions albeit for only a short duration. This can result in damage to the components through which this current surge flows and in some cases can result in premature failure. Fuses, traditionally used to protect circuits from such overloads, now have to be specially selected to fail only under specific conditions of current and duration. Some of the solutions designers have used to limit these transients and minimise the problems vary from positive temperature co-efficient resistors right through the spectrum of technology to 'soft-start' techniques to gradually ramp up the supplies. Few of these ever meet the all important criteria of reliability and low cost. The circuit above shows one such application; a battery charger. In this application the customer required the resistor to withstand an inrush surge,

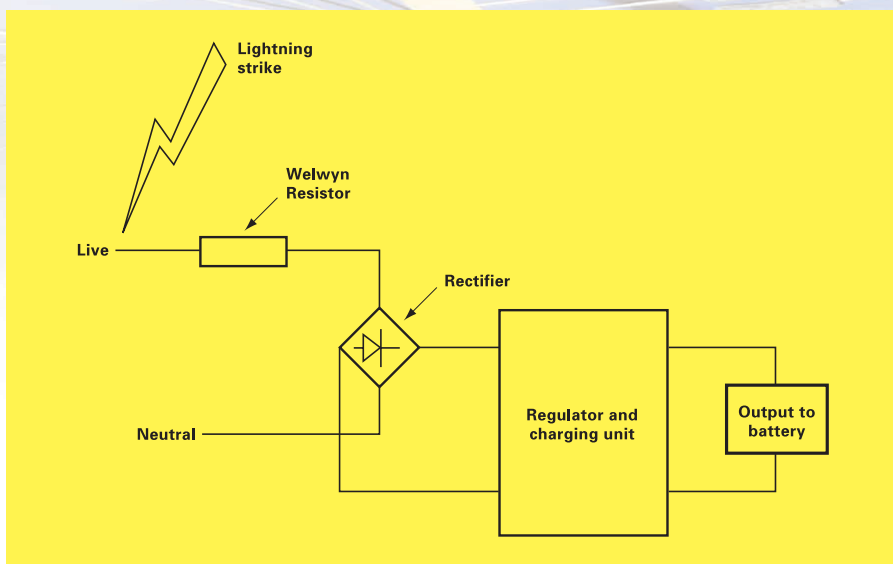

and also a lightning strike. The lightning strike is usually simulated by either a 1.2/50 microsecond or 10/700 microsecond pulse shape, the number of pulses and pulse interval are specified by the customer depending upon the application. An additional feature which is required for this type of circuit is the ability of the resistor to fuse safely should a short circuit occur (for example if the bridge

rectifier were to fail short circuit). Typical parts used are WFF series (Fast Fusible Metal Film) and WA series (Cement Coated Wirewound) resistors often with special features to meet specific application requirements. Both of these parts have defined energy handling capabilities. Special versions can be produced to withstand customer defined pulses and/or to fuse during defined conditions of overload.

## Fast Fusible Metal Film Resistors

### WFF Series

- Low power fusing
- Predictable fusing characteristics
- Flameproof protection

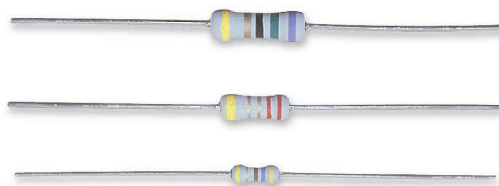

### Electrical Data

		WFF1/4	WFF1/2	WFF1
Power rating at 70°C	watts	0.25	0.5	1
Resistance range	ohms	0R1 - 10K	0R1 - 27K	0R2 - 1K5
Limiting element voltage	volts	250	350	350
TCR	ppm/°C		250	
Resistance tolerance	%		5	
Standard values			E24 preferred	
Thermal impedance	°C/watt	150	120	100
Ambient temperature range	°C		-55 to 155	

## General Purpose Cement Coated Wirewound Resistors

### WA80 Series

- Cost effective
- Flameproof protection
- Can replace carbon comp. in many applications
- Resistance values down to 0.01 ohms
- Ideal for pulse handling applications

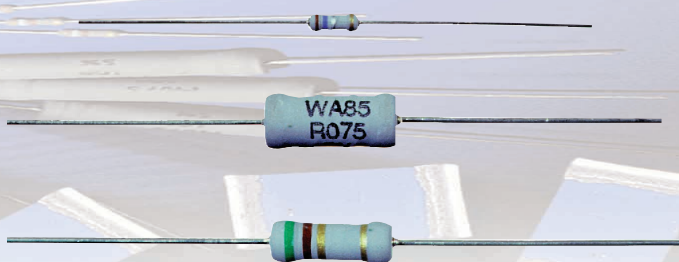

### Electrical Data

		WA82	WA83	WA835	WA84	WA85	WA87
Power rating at 25°C	watts	1	2.0	2.5	3.0	5	7
Power rating at 70°C	watts	0.86	1.6	2.0	2.5	4.3	6
Resistance range	ohms	0R068 - 430R	0R05 - 900R	0R05 - 900R	0R01 - 2K2	0R015 - 4K5	0R15 - 10K
Limiting element voltage	volts	50	50	75	100	150	150
Isolation voltage	volts	250	250	250	350	500	700
TCR	ppm/°C	<math><1\Omega:350</math>			>math>>1\Omega:200</math>		
Resistance tolerance	%	5, 10					
Standard values	E24 preferred						
Thermal impedance	°C/watt	140	110	82	90	54	35
Ambient temperature range	°C	-55 to 155					

## Pulse Withstanding Fusible Flameproof Metal Film Resistors

### EMC Series

- UL1412 recognised\*
- Failsafe 240V mains fusing
- Good pulse handling capability
- Small size for power rating
- UL94-V0 flameproof protection

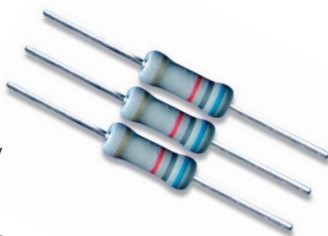

\* Values 22R and above. UL file number E234469

### Electrical Data

		EMC2
Power rating at 70°C	watts	2
Resistance range	ohms	4R7 - 68R
TCR	ppm/°C	100
Isolation Voltage	Volts	500
Resistance tolerance	%	10, 20
Standard values		E12
Thermal impedance	°C/watt	82
Ambient temperature range	°C	-55 to +155

For full details on this product, see our Application Note 'UL Recognised Fusible Resistors'

Another application involving current limiting is in EMI filters, often found in power supplies and lighting circuits. The circuit right shows a typical EMI filter and the location of the safety resistor, parts used include FM series and WFF (Fast Fusible Metal Film Resistors). The resistor is chosen/designed to withstand a specified inrush surge and to fuse safely should a fault occur.

For applications requiring very high energy pulses or very high inrush surges Welwyn have a range of Vitreous Enamelled resistors with high overload

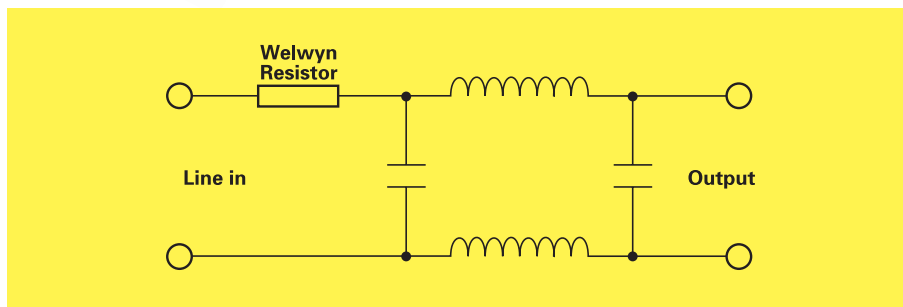

capability and defined energy handling which are perfectly suited. These are available in five standard body sizes with

power ratings of 3 to 14W. Welwyn also has the ability to design custom parts for specific applications.

### 3. Short Circuit or Overload Protection

Many power supplies incorporate some form of short circuit or overload protection (sometimes called over current protection) in their output stage. Protection in older circuits was often achieved using a simple bimetallic switch in series with the output. However these proved to be inaccurate, slow to react and unreliable in operation. Modern circuits now use an electronic method to monitor the power supply output current and to control the output should a fault occur. A typical example is shown overleaf in the form of a series voltage regulator with constant current limiting (the current limiting section of the circuit is high lighted). The load current ( $I_L$ ) passes through the sense resistor  $R_{SENSE}$  and creates a voltage between the base and emitter of transistor  $T_2$ . When  $I_L$  reaches a preset maximum value, the voltage drop across  $R_{SENSE}$  is sufficient to forward bias the base-emitter junction of  $T_2$  causing it to conduct. This diverts the base current from  $T_1$  into the collector of  $T_2$  so that  $I_L$  is limited to its maximum value.

The resistor needs to be carefully selected, firstly to give the correct voltage drop for the intended maximum output current and secondly because the full load current will pass through it. Obviously power ratings will vary with the specific power supply and value selected.

Welwyn can offer a wide range of current sense products. One of the most compact and versatile is the LR series of low value chip resistors. For other options, see our Application Note "Current Sense Resistors".

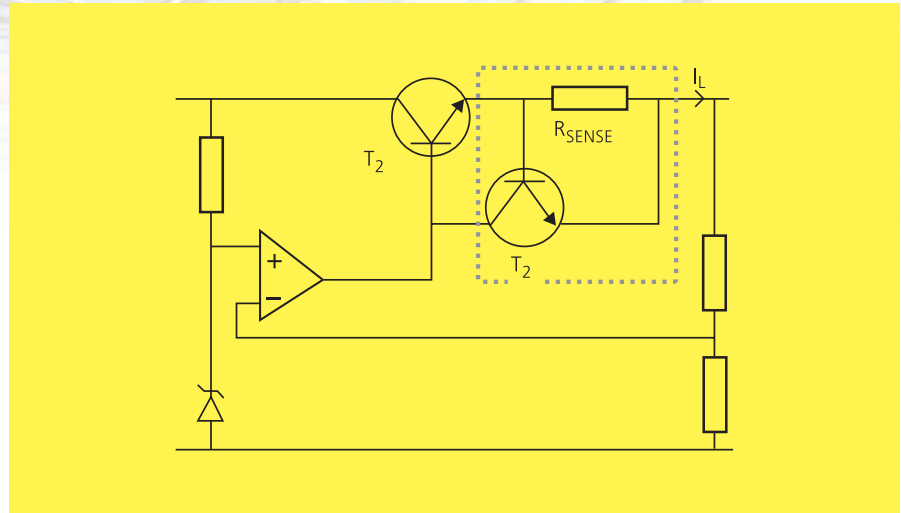

### Low Value Flat Chip Resistors

#### LR Series

- Resistance values down to 0.003 ohms
- Leach resistant solder plated copper wrap around termination
- Low inductance - less than 0.2nH

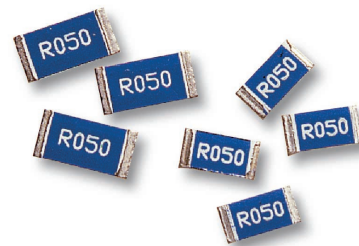

#### Electrical Data

		LR1206	LR2010	LR2512	LRF3W	LRK2512
Power rating at 70°C	Watts	0.5	1.0	1.5   2.0	3.0	2.0
Resistance range	Ohms	0R003 - -10R			0R003 - 0R1	
Tolerance	%	<0R01 : 5% ≥0R01 : 1,2,5%	1, 2, 5%			
Number of terminals		2	2	2	2	4
Dielectric withstand	Volts	200	200	200	200	200
TCR	ppm/°C	≥0R05 : 100	≥0R05 : 100	≥0R05 : 100	≥0R01 : 100	≥0R01 : 100
Temperature rise at rated power	°C	40	80	90	100	70
Total pad & trace area for rated power at 70°C	mm <sup>2</sup>	30	30	100   300	300	300
Nominal dimensions L x W	mm	3.20 x 1.63	5.23 x 2.64	6.50 x 3.25	3.25 x 6.50	6.50 x 3.25
Termination style		≤0R025 Flip-chip, >0R025 Normal			Flip-chip	

## 4. Telecommunications

Telephone lines can be subjected to a large range of voltage disturbances, many of which can damage switching equipment. This has led to the need for circuit protection against both high voltage transients, usually of short duration due to lightning strikes and overloads of longer duration caused by accidental direct connection to mains power lines.

These two faults are separated into primary and secondary protection. Primary protection handles the high voltage transients, and is usually located within the exchange. Secondary protection is usually built into the equipment to be protected, and deals with both current and voltage limiting. Voltage limiting prevents damage to the equipment and shock hazards, and current limiting prevents damage to wiring and voltage limiters.

A typical application circuit is shown right where the resistors are designed for ring signal sending through a solid state relay. The resistors are protected from lightning surge by Over-voltage Protection in the system and the resistors are required to withstand pulse of 15 Watts for 1 second and 75 Watts for 0.1 second, repeated 60 times.

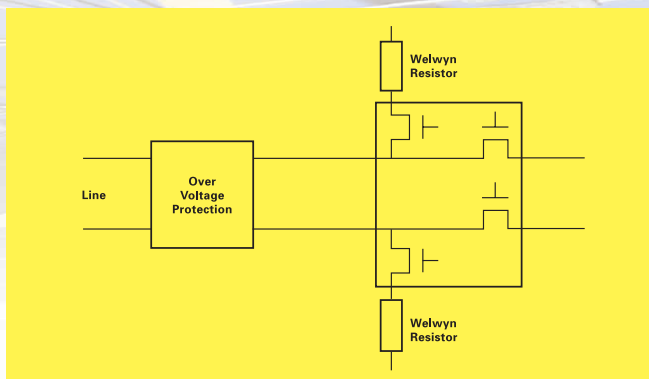

For this application, Welwyn has developed the Pulse Withstanding Chip (PWC series) described below. For full details on this product, see our Application Note "Pulse Withstanding Chip Resistors".

### Pulse Withstanding Chip Resistors

PWC Series

#### Electrical Data

Size	0805	1206	2010	2512
Power @70°C	0.125W	0.33W	0.75W	1.5W
Resistance range	1R0 to 10M			
Tolerance	0.5, 1, 2, 5%			
LEV	150V	200V	400V	500V
TCR	<10R:200ppm/°C ≥10R:100ppm/°C			
Operating temperature	-55 to +155°C			
Values	E96 preferred other values to special order			
Pulse capability	See following pages			

- Excellent pulse handling performance
- Thick film technology provides wide resistance and temperature ranges (1ohm to 10 meg ohm; -55 to +155°C)
- Standard and custom chip sizes (0805 to 2512)

Note: Circuit diagrams shown for example only.

For more detailed product information and data sheets or to discuss your specific requirements please contact Welwyn Components Ltd.

**Welwyn Components Ltd. have over 60 years experience  
in designing and manufacturing resistive components.**

#### Welwyn Components Limited

Welwyn Electronics Park, Bedlington  
Northumberland NE22 7AA, UK

Telephone: +44 (0) 1670 822181  
Facsimile: +44 (0) 1670 829465  
Email: info@welwyn-tt.com

Website: [www.welwyn-tt.com](http://www.welwyn-tt.com)

#### IRC Inc. (AFD)

4222 South Staples Street  
Corpus Christi, Texas 78411, USA

Telephone: +1 361 992 7900  
Facsimile: +1 361 992 3377  
Email: ircafd@ircct.com

Website: [www.ircct.com](http://www.ircct.com)

 **electronics**  
Excellence in Technology

**General Note** Welwyn Components reserves the right to make changes in product specification without notice or liability. All information is subject to Welwyn's own data and is considered accurate at time of going to print.

Subsidiaries of TT electronics plc