

Pulse Withstanding Chip Resistors

PWC Series

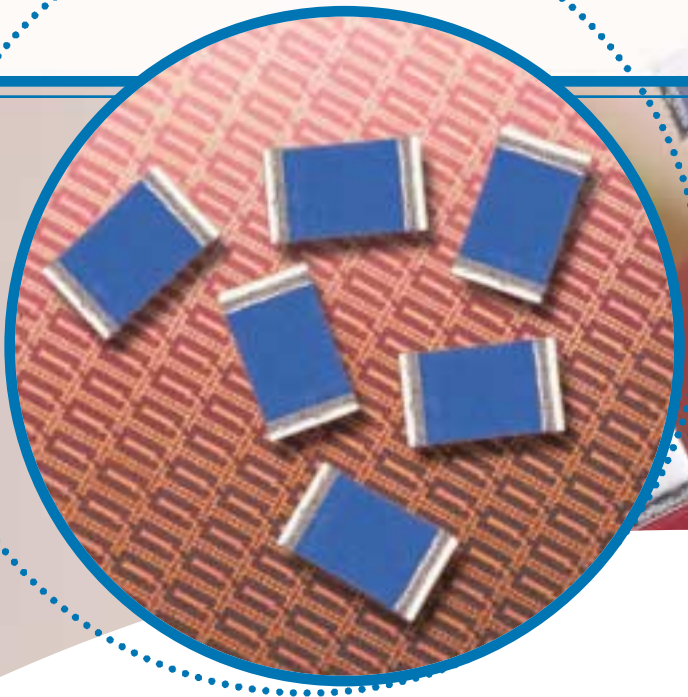

Today's electronic devices are becoming smaller and smaller. As a result designers are moving more towards surface mount components not only for new designs but also to design out large axial and other through-hole resistors. In most cases this is a straightforward task as several resistor manufacturers offer chip resistors with performances to match axial parts. However in some cases, due to power rating or pulse withstanding requirements, this has been impossible. The requirement, in particular, for pulse withstand capability is growing due to the need to protect sensitive modern electronic systems.

To meet this demand Welwyn have designed a Pulse Withstanding Chip Resistor (PWC Series). The PWC series is available in four standard sizes from 0805 to 2512 as shown in the following table. The table also gives details of the improved LEV (Limiting Element Voltage) and increased power rating. Pulse withstanding details are given on the following pages.

The enhanced performance of the chips is made possible by the precise use of the best resistance inks and a closely controlled production process.

- **Excellent pulse handling performance**
- **Cost effective custom designs available**
- **Field proven with millions of units in use**
- **Standard and custom chip sizes (0805 to 2512)**



Subsidiaries of TT electronics plc

Size	0805	1206	2010	2512
Power @70°C	0.125W	0.33W	0.75W	1.5W
Resistance range	1R0 to 10M			
Tolerance	0.5*, 1, 2, 5%			
LEV	150V	200V	400V	500V
TCR	<10R:200ppm/°C ≥10R:100ppm/°C			
Operating temperature	-55 to +155°C			
Values	E96 preferred other values to special order			
Pulse capability	See following pages			

*0.5% Tolerance only available on values 10R to 1MΩ.

Applications

Applications vary from line protection for telecommunications to surge withstanding resistors for use in circuit breakers. Details of a typical telecomm and power supply application are given below.

Telephone lines can be subjected to a large range of voltage disturbances, many of which can damage switching equipment. This has led to the need for circuit protection against both high voltage transients, usually of short duration caused by lightning strikes and overloads of longer duration, due to direct connection to mains power lines.

These two faults are separated into primary and secondary protection. Primary protection handles the high voltage transients, and is usually located within the exchange. Secondary protection is usually built into the equipment to be protected, and deals with both current and voltage limiting.

Voltage limiting prevents damage to the equipment and shock hazards, and current limiting prevents damage to wiring. A typical application circuit is shown in fig 1 where the resistors are designed for ring signal sending through a solid state relay. The resistors are protected from lightning surge by Over-voltage

protection in the system and the resistors are required to withstand pulses of 15 Watts for 1 second and 75 Watts for 0.1 second, repeated 60 times. Test requirements for telecomm applications are laid down by the International Telecommunications Union (ITU) and Bell Communications Research (Bellcore).

Fig 2 shows a typical power supply or battery charger circuit. In this application the resistor is required to withstand a small inrush surge, and also a lightning strike surge. The lightning strike is usually simulated by applying either a 1.2/50µs or 10/700µs pulse shape, the number of pulses and pulse intervals being specified by the customer or the relevant standard. Typical standards to be met are Cenelec EN50082-1 and EN50082-2 which are part of the European EMC directives.

To determine the suitability of a PWC series chip resistors for your application refer to the pulse withstanding data as given below. Graphs have been produced to show the PWC performance under single and continuous pulse, maximum pulse voltage for single and continuous pulses and lightning surge performance using both 1.2/50µs and 10/700µs pulse shapes.

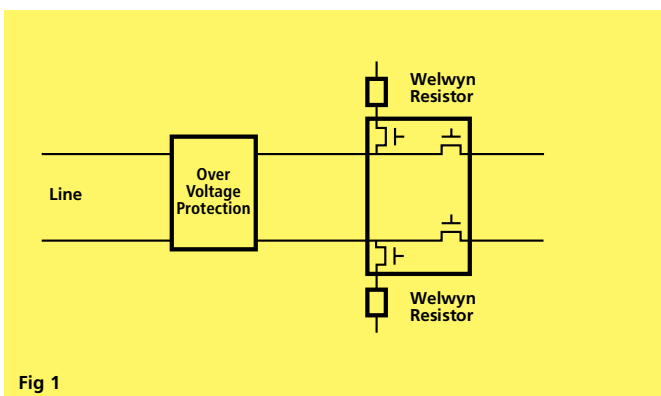

Fig 1

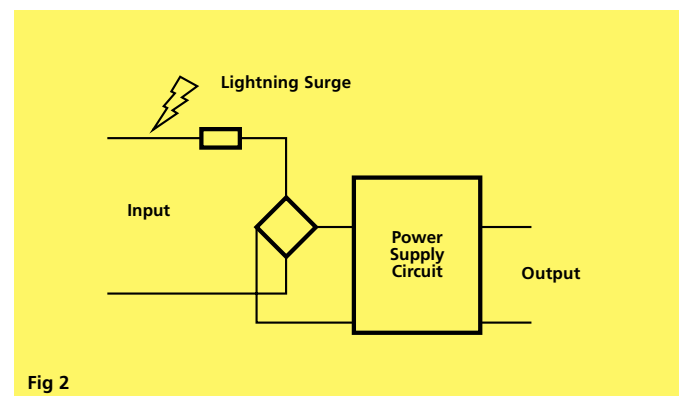

Fig 2

Description of Performance Tests

Single Impulse

The single impulse graph was the result of 50 impulses of rectangular shape applied at one minute intervals. The limit of acceptance was a shift in resistance of less than 1% from the initial value. The power applied was subject to the restrictions of the maximum permissible impulse voltage graph as shown.

Continuous Load Due to Repetitive Pulses

The continuous load graph was obtained by applying repetitive rectangular pulses where the pulse period (t_p) was adjusted so that the average power dissipated in the resistor was equal to its rated power at 70°C. Again the limit of acceptance was a shift in resistance of less than 1% from the initial value.

The formula used to calculate the average power for repetitive pulses is shown below.

$$\text{For a rectangular impulse } P = \frac{V^2 t_i}{R t_p} \leq P_{nom}$$

$$\text{For an exponential impulse } P = \frac{V^2 t_e}{R 2t_p} \leq P_{nom}$$

Where R = nominal resistance

t_p = time of the pulse period
($1/t_p$ = pulse frequency)

V = peak voltage of the impulse

P = average power dissipation
of continuous pulses

t_i = impulse time of a rectangular pulse

T_e = time constant of an exponential pulse

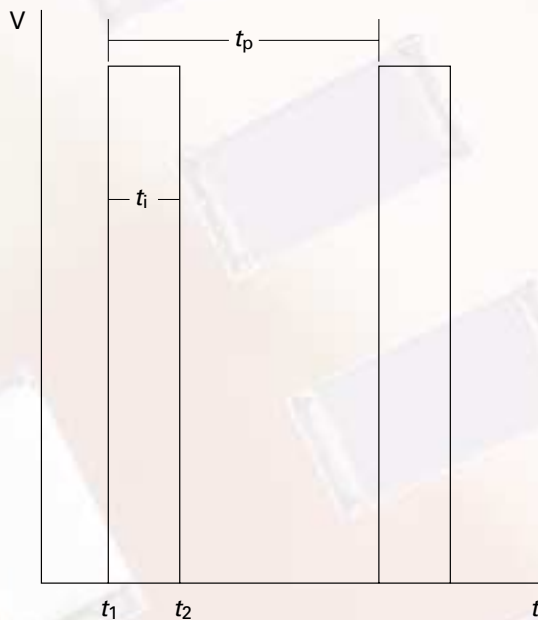

Rectangular Pulses

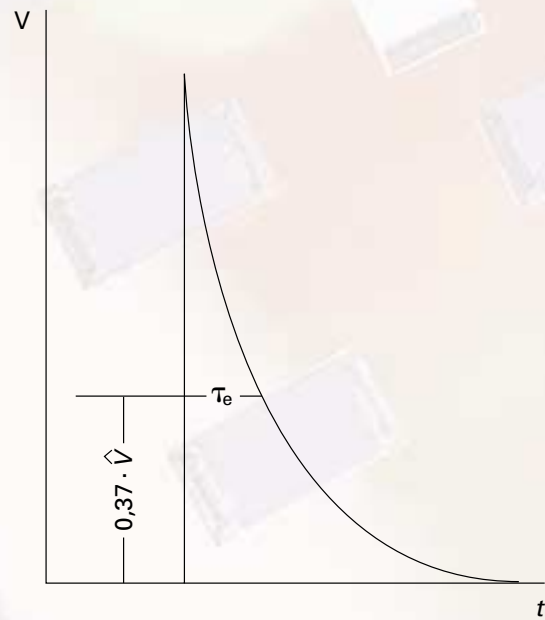

Exponential Pulse

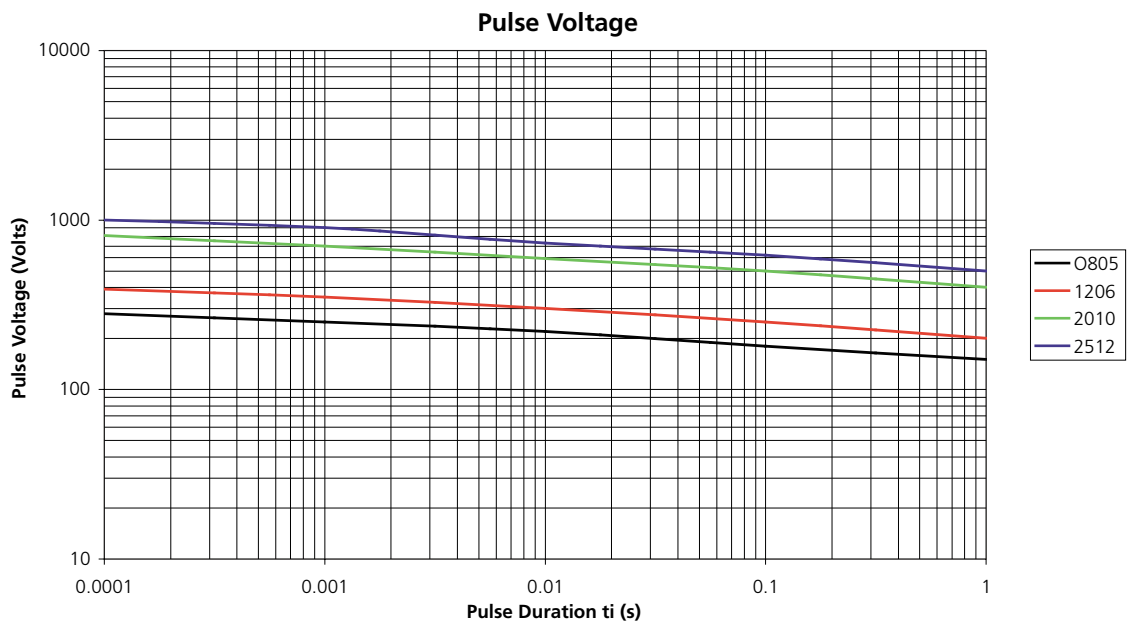
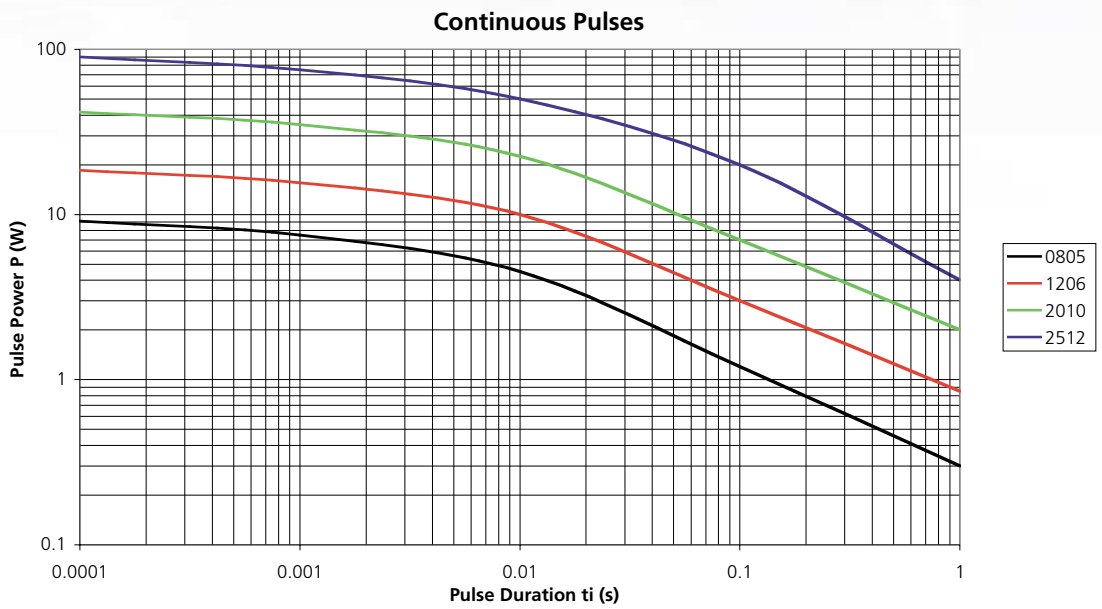
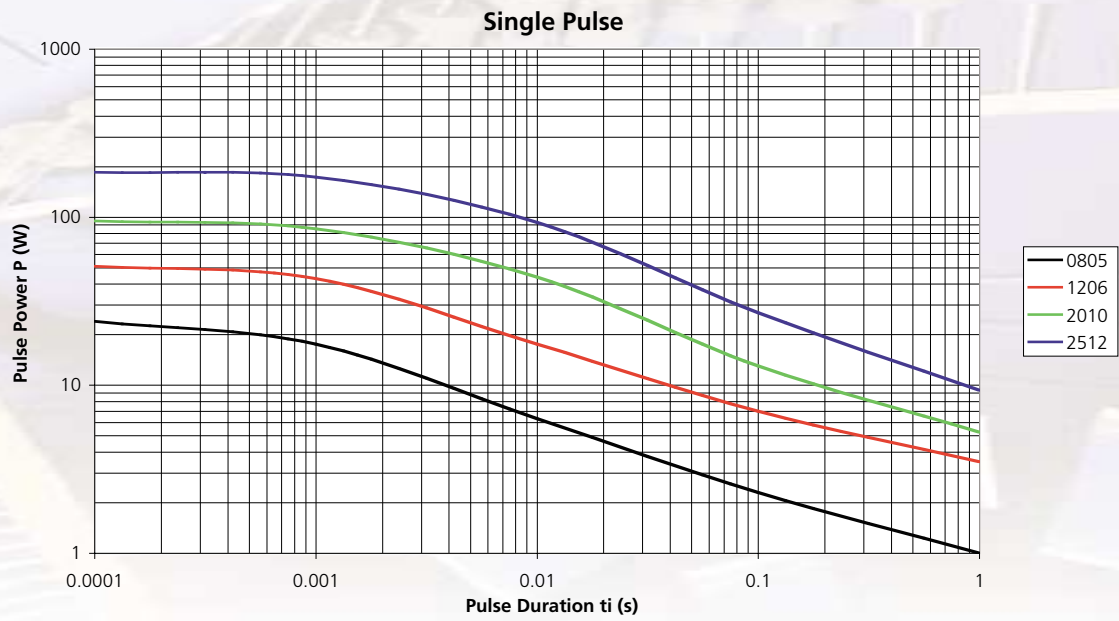

Lightning Surge

Resistors are tested in accordance with IEC 60 115-1 using both 1.2/50 μ s and 10/700 μ s pulse shapes. The limit of acceptance is a shift in resistance of less than 1% from the initial value.

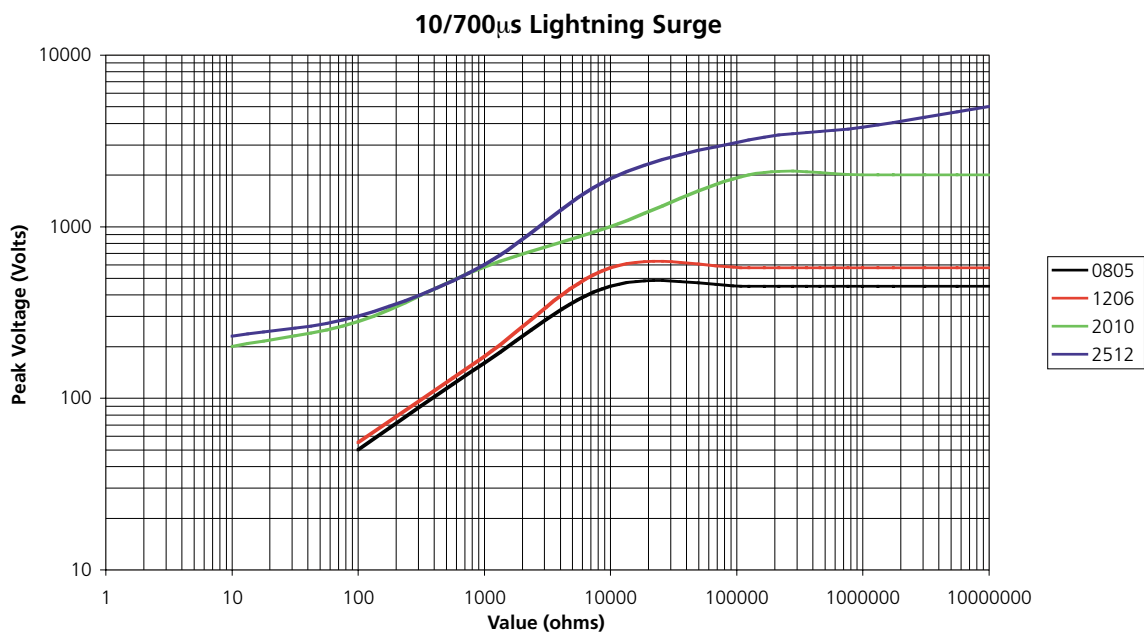
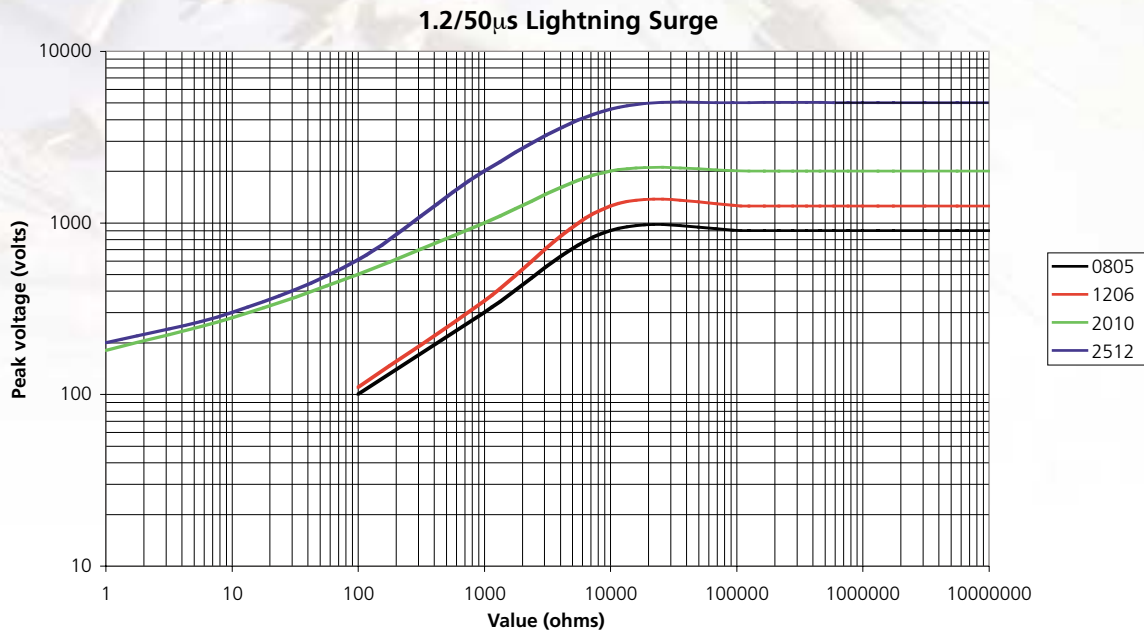

Performance Data

		Maximum	Typical
Load at rated power: 1000 hours at 70°C	ΔR%	2	0.25
Shelf life: 12 months at room temperature	ΔR%	0.1	0.02
Derating from rated power at 70°C		Zero at 155°C	
Overload: 6.25 x rated power for 5 seconds	ΔR%	1	0.1
Dry heat: 1000 hours at 155°C	ΔR%	1	0.2
Long term damp heat	ΔR%	1	0.25
Temperature rapid change	ΔR%	0.25	0.05
Resistance to solder heat	ΔR%	0.25	0.05
Voltage proof	Volts	500	

Note: An 0.01 ohm addition to be added to the performance of all resistors <10 ohms.

Physical Data

Dimensions of PWC chips are given below in mm and weight in g.

	L	W	T max	A	B*	C	Wt.	
0805	2.0±0.3	1.25±0.2	0.6	0.3±0.15	0.9 min	0.3±0.1	0.009	
1206	3.2±0.4	1.6±0.2	0.7	0.4±0.2	1.7 min	0.4±0.15	0.020	
2010	5.1±0.3	2.5±0.2	0.8	0.6±0.3	3.0 min	N/A	0.036	
2512	6.5±0.3	3.2±0.2	0.8	0.6±0.3	4.4 min	N/A	0.055	

* This dimension determines the number of conductors which may pass under the surface mounted chip.

Construction & Solderability

Thick film resistor material, overglaze and organic protection are screen printed on a 96% alumina substrate. Wrap-around terminations have an electroplated nickel barrier and tin-lead

solder coating, this ensures excellent 'leach' resistance properties and solderability. Chips can withstand immersion in solder at 260°C for 30 seconds.

**Welwyn Components Ltd. have over 60 years experience
in designing and manufacturing resistive components.**

 **electronics**
Excellence in Technology

Welwyn Components Limited

Welwyn Electronics Park, Bedlington
Northumberland NE22 7AA, UK

Telephone: +44 (0) 1670 822181
Facsimile: +44 (0) 1670 829465
Email: info@welwyn-tt.com

Website: www.welwyn-tt.com

IRC Inc. (AFD)

4222 South Staples Street
Corpus Christi, Texas 78411, USA

Telephone: +1 361 992 7900
Facsimile: +1 361 992 3377
Email: ircafd@irctt.com

Website: www.irctt.com

General Note Welwyn Components reserves the right to make changes in product specification without notice or liability. All information is subject to Welwyn's own data and is considered accurate at time of going to print.

Subsidiaries of TT electronics plc