

Specification of Li-ion Rechargeable Battery

Model No.: 18650CA-2S-3J

Reported by: 陈声宇 Date: Oct,17,2013
Checked by: _____ Date : _____
Approved by: _____ Date: _____

1. Scope

This specification describes the definition, technical requirement, testing method, warning

and caution of the Lithium ion rechargeable battery.

2. Product Model

2.1 Battery type: Lithium ion rechargeable battery pack

2.2 Model No.: 18650CA-2S-3J

3. Basic Specification

3.1	Nominal voltage	7.4V
3.2	Nominal capacity	2250mAh (0.2C discharged from 4.2V to 2.75V each cell)
	Minimum capacity	2150mAh (0.2C discharged from 4.2V to 2.75V each cell)
3.3	Charge voltage	4.20±0.05V<each cell>
3.4	Standard charge current	0.5C(1100mA)
	Max charge current	1C (2200mAh, 10°C≥T≥0°C)
3.5	Charge conditions	CC / CV
3.6	Max continuous discharge current	1C (2200mA)
3.7	Max peak discharge current	1C (2200mA)
3.8	Discharge cut-off voltage	3.0V±0.075V<each cell>
3.9	Thermister	10K NTC((±5%)
3.10	Internal Impedance	≤200mohm (after charged)
3.11	Working temperature	Charge: 0 ~ +45°C
3.12		Discharge: -20 ~ +60°C
3.13	Storage temperature	-20 ~ +45°C<recommend -0~35°C>
3.14	Relative humidity	65±20%
3.15	Weight	Approx 100g <for battery pack>
3.16	Battery pack dimension	Thickness: 18.6mm<±0.3mm>
		Width : 37.3mm<±0.5mm >
		Length : 70.0mm<±0.5mm >

4. Visual Inspection

There shall be no such defects as remarkable scratches, cracks, bolts, cup cancers, deformations, swelling, leakage.

5. Detailed Specification

5.1 Electrical specification<for each cell>

Items	Test conditions	Results
5.1.1 Full charge <standard charge>	Under $20\pm 5^{\circ}\text{C}$, $65\pm 5\%\text{RH}$, it can be charged to 4.2V with constant current of $0.2C_5\text{mA}$, And then, charged continuously with constant voltage of 4.2V until the charged current is less than $0.02 C_5\text{mA}$.	Remark: it is standard charge method
5.1.2 Rated capacity	Under $20\pm 5^{\circ}\text{C}$, charge the cell according to above charging method, then, keep it for 0.5-1hrs. Discharge the cell with constant current $0.2C_5\text{mA}$ to 2.75V, the discharging time is not less then 5 hours.	$\geq 2250\text{mAh}$
5.1.3 Cycle life	Discharge the cell with constant current $0.2C_5\text{mA}$ to 2.75V firstly, then, charged it for 2.5hrs by quick charging, keep it for 30mins. Discharge it with current $1C_5\text{mA}$ to 2.75V, this is one cycle. To do the cycle test for 300^{f} times.	Capacity \geq at least 80% of the rated capacity
5.1.4 Internal impedance	At 1kHz AC with fully charge state	Initial battery pack $\leq 200\text{m}\Omega$
5.1.5 Temperature performance	Hi-temperature: At $20\pm 5^{\circ}\text{C}$, charge the cell according to standard charge, then, keep it in the oven of $55\pm 2^{\circ}\text{C}$ for 2hrs. Discharge the cell with constant current of $0.5 C_5\text{mA}$ to 2.75V, the discharging time should be not less than 51 minutes.	
	Low temperature: At $20\pm 5^{\circ}\text{C}$, charge the cell according to standard charge, then, keep it in the oven of $-20\pm 2^{\circ}\text{C}$ for 16 ~ 24 hrs. Discharge the cell with constant current $0.2 C_5\text{mA}$, the discharge time should be not less than 3hrs.	
	Constant temperature & humidity: At $20\pm 5^{\circ}\text{C}$, charge the cell according to standard charge, then, keep it in $40\pm 2^{\circ}\text{C}$ & $90\sim 95\%\text{RH}$ for 48hrs, after this, keep the cell in $20\pm 5^{\circ}\text{C}$ for 2hrs. Discharge the cell with constant current of $0.5 C_5\text{mA}$ to 2.75V, the discharge time should be not less than 36mins.	
5.1.6 Storage	Storage for 28 days at 25°C .	Capacity $\geq 80\%$
	Storage for 7 days at 60°C .	Capacity $\geq 85\%$
5.1.7 Open circuit voltage	As of shipment<battery pack>	7.6 – 8.1V

6.1 Mechanical specification<for each cell>

Items	Test conditions
6.2.1 Vibration test	At 20±5°C & normal atmospheric pressure, charge the cell according to standard charge. Then, vibrated it 10 times in each direction of X, Y, Z with changing frequency of 10~55HZ and amplitude of 0.35mm, the rate of scan frequency is from 10~55HZ per min. After above test, to keep the battery at 20±5°C for 30mins, the battery cannot be break, scratch, distortion, contamination and leakage, and the Voltage is not less than 3.6V.
6.2.2 Free fall testing	At 20±5°C, charge the cell by standard charging, then drop it freely for six times in each direction of X, Y, Z from the height of 1000mm onto the hard board with the thickness of 20mm. After above testing, to keep the cell at (20±5)°C for 1-2hrs, the cell cannot be break, scratch, distortion, contamination and leakage. Discharge the cell to 2.75V with constant current 0.2 C ₅ mA, it should be discharged and the discharge time should be not less than 51 minutes.

6.3Secure Specification<for each cell>

Items	Test conditions
6.3.1 Impact Testing	At 20±5°C, full charge the cell by standard charge, then, place the cell on the impact flat, a 10kgs weight dropped from 1m height onto cell, distortion is allowed. After above testing, to keep the battery at 20±5°C for 1-2hrs, the cell should be not exploded or catch fire.
6.3.2 Heat impact testing	Put the cell into a air oven, the temperature in the oven should rise at the rate of speed of (5±2°C)/min to be 130°C±2°C, keeping the temperature for 30 min, the cell should be not explosion, fire or fume.
6.3.3 Short-circuit test	At 20±5°C, full charged the cell by standard charge firstly, short-circuited it by max resistance of 50mΩ by connecting the positive and negative terminals of cell with copper wire, Monitor its temperature while testing, finish the test when the cell case temperature was 10°C lower than the peak temperature. The cell should be not explosion, fire.
6.3.4 Over-charged test	Connect the cell with a CC/CV power, then, charge the cell to 4.6V with constant 3A current, and last for 2hrs. The cell shall be not explode and fire.
6.3.5 Over-discharged test	At 20±5°C, charged the cell by standard charge firstly, then, discharge it with constant current 0.2 C ₅ mA to 2.75V. Connected with external load of 30Ω for 24hrs. The cell shall be not explode or fire.

7. Test Conditions

Temperature : 25±2°C

Relative humidity : 65±20%

8. Warranty

The period of validity of the cell is 12 months.

9. Warnings

9.1 Warning:

To prevent the possibility of the battery from leaking, heating and explosion. Please observe the following precautions:

- Don't immerse the battery in water and seawater. Please put it in cool and dry environment if no using.
- Do not use and leave the battery near a heat source as fire or heater.
- Being charged, using the battery charger specifically for that purpose.
- Don't reverse the positive and negative terminals.
- Don't connect the battery to an electrical outlet directly.
- Don't discard the battery in fire or heater.
- Don't connect the positive and negative terminal directly with metal objects such as wire.
- Do not transport and store the battery together with metal objects such as necklaces, hairpins.
- Do not strike, throw or trample the battery.
- Do not directly solder the battery and pierce the battery with a nail or other sharp object.

9.2 Caution:

- Do not use or leave the battery at very high temperature conditions (for example, strong direct sunlight or a vehicle in extremely hot conditions). Otherwise, it can overheat or fire or its performance will be degenerate and its service life will be decreased.
- Do not use it in a location where is electrostatic and magnetic greatly, otherwise, the safety devices may be damaged, causing hidden trouble of safety
- If the battery leaks, and the electrolyte get into the eyes. Do not wipe eyes, instead, rinse the eyes with clean running water, and immediately seek medical attention. Otherwise, eyes injury can result.
- If the battery gives off an odor, generates heat, becomes discolored or deformed, or in any way appear abnormal during use, recharging or storage, immediately remove it from the device or battery charge and stop using it.
- In case the battery terminals are dirt, clean the terminals with a dry cloth before use. Otherwise power failure or charge failure may occur due to the poor connection with the instrument.
- Be aware discharged batteries may cause fire; tape the terminals to insulate them.

10. Data sheet for PCM

10.1) Performance test Parameter

Main parameter $T_{opt}=25^{\circ}\text{C}$
--

Item	Symbol	Description	Min	Standard	Max	Unit
Over-charge protection	V _{CU}	Over-charge test Vol	4.265	4.29	4.315	V
		Over-charge renew vol	4.0	4.05	4.1	V
	t _{CU}	Delay time of over-charge protection	0.7	1	1.3	S
Over-discharge protection	V _{DL}	Over-discharge test vol	2.925	3.0	3.075	V
		Over-discharge renew vol	3.12	3.2	3.28	V
	t _{DL}	Delay time of over-discharge protection	89	128	167	MS
Over-current	V _{IOV1}	Over-current protect test vol	0.185	0.20	0.215	V
	t _{IOV1}	Delay time of over-current protection	8	12	16	MS
		Max discharge current	5	-	8	A
		Renew condition from protection	Disconnect the load			
Short-circuit protect	V _{SHORT}	Short-circuit protect test vol	0.7	1.1	1.5	V
	t _{SHORT}	Delay time of short-circuit protection	150	300	500	μS
Self-discharge	I _{PDN}	Static self-discharge	-	-	0.1	μA
	I _{OPe}	Internal self-discharge during working condition	-	4.0	8.0	μA

10.2 PCM BOM list:

No.	Code	Name	SPEC	Assembling method	QTY	Unit
1	U1	Control IC	R5460N212AF	SOT-23-6	1	PC
2	U2	MOSFET	AO8822	TSS0P-8B	1	PC
3	R1	SMD Resistor	330Ω ±5% SMD	0603	1	PC

4	R2	SMD Resistor	330Ω ±5% SMD	0603	1	PC
5	R3	SMD Resistor	1KΩ ±5% SMD	0603	1	PC
6	C1	SMD Capacitor	0.1μF -20/+80% 25V SMD	0603	1	PC
7	C2	SMD Capacitor	0.1μF -20/+80% 25V SMD	0603	1	PC
8	C3	SMD Capacitor	0.01μF -20/+80% 25V SMD	0603	1	PC
9	PCB	board	35±0.2*15±0.2*1.0±0.1mm	XYP-DUB2S-028	1	PC

10.3 PCM layout

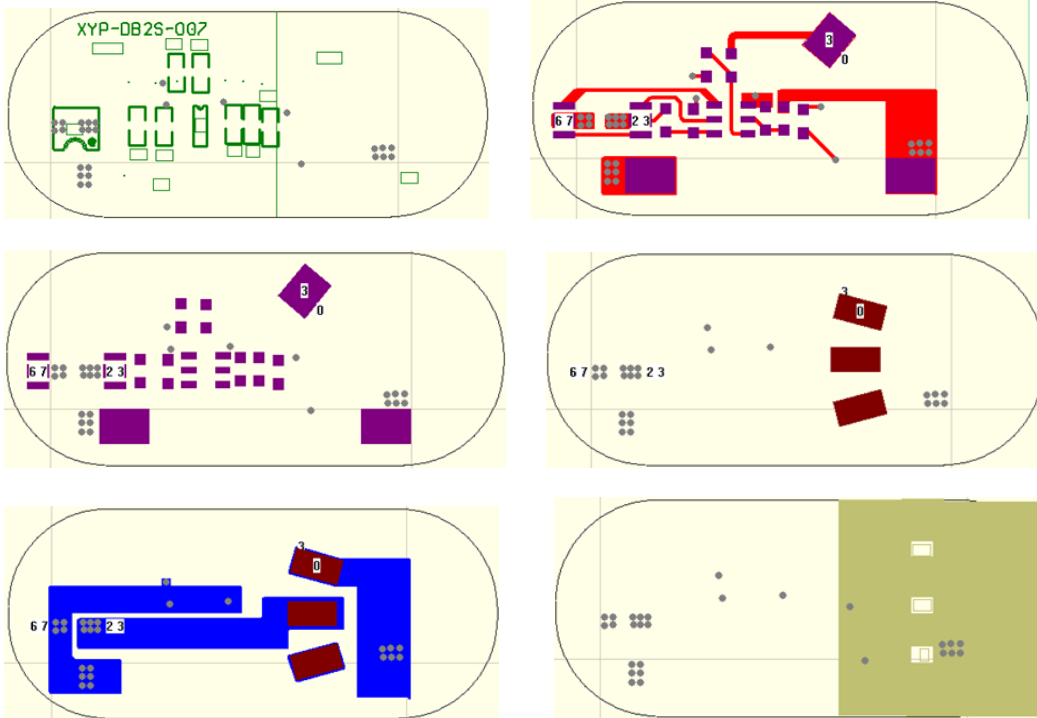

10.4 PCM diagram

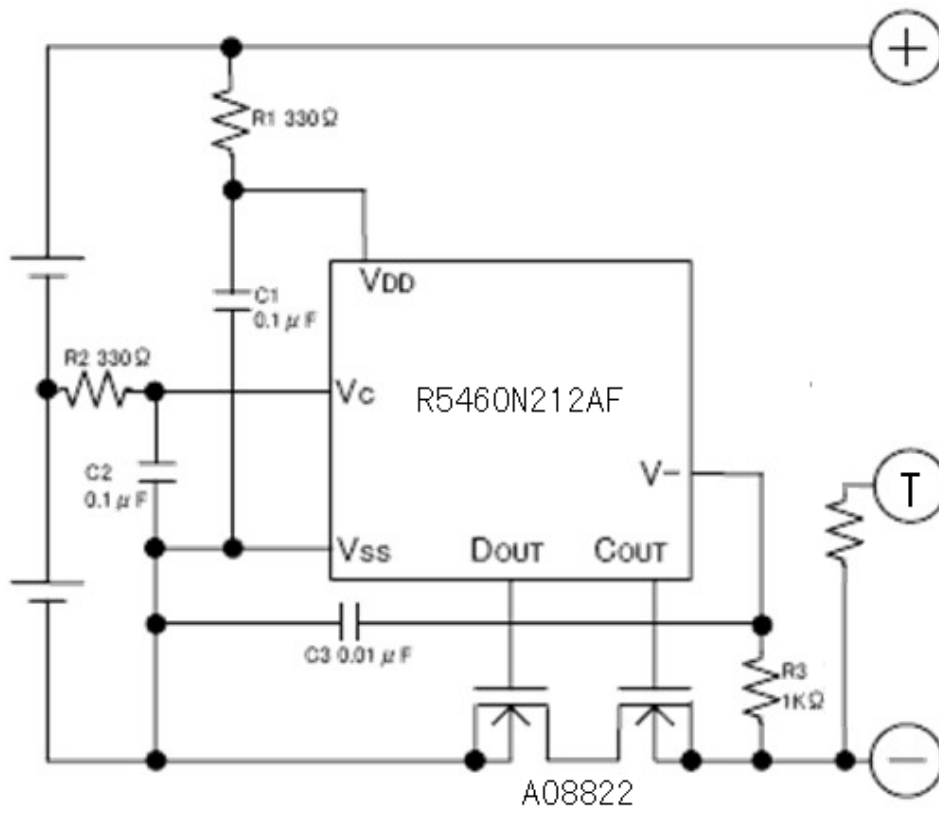

11. Drawing of battery pack:

