

Compact and highly reliable type available in many varieties

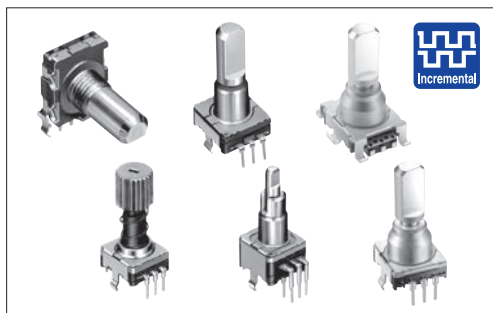

### Typical Specifications

Items	Specifications
Output signal	Two phase of A, B Self-return switch (EC111 / EC11E0B)
Rating	10mA 5V DC
Operating life	15,000 cycles 100,000 cycles (EC11K / EC11J)
Operating temperature range	-40°C to +85°C

### Product Line

Structure	Shaft configuration	Length of the shaft (mm)	Torque (mN·m)	Number of detent	Number of pulse	Push-on switch	Travel of push-on switch (mm)	Operating life (cycles)	Minimum order unit (pcs.)		Product No.	Drawing No.									
									Japan	Export											
Horizontal			12±7	30	15	Without	—	15,000	700	1,400	EC11B15202AN	1									
						With	0.5				EC11B15242AZ	2									
							1.5				EC11B15242B1	3									
Vertical	Flat	20	10±7	18	9	Without	—	15,000	1,200	2,400	EC11E09204A4	4									
				30	15						EC11E15204A3										
				36	18						EC11E1820402										
				18	9						EC11E09244BS	5									
				30	15						EC11E15244G1										
				7 ± $\frac{3}{4}$	Without						15		EC11E153440D								
			10±7	36	18	EC11E18244AU															
			7 ± $\frac{3}{4}$	Without	18	EC11E183440C															
			10±7	18	9	EC11E09244AQ															
						12±7	30				15	With	0.5				EC11E15244B2				
																	7 ± $\frac{3}{4}$		Without	15	EC11E1534408
																	10±7		36	18	EC11E18244A5
7 ± $\frac{3}{4}$	Without	18						EC11E1834403													
10±7	36	18																			
7 ± $\frac{3}{4}$	Without	18																			
Less shaft wobble	Serrated	25	12±7	30	15	Without	—	15,000			EC11G1560414	6									
			8.5±5	Without		1.5	EC11G1574402				7										
			12±7	30		EC11G1564411	8														
Vertical	Flat	20	12±5	18	9	Without	—	100,000	1,000	2,000	EC11K0920404	9									
				30	15						EC11K1520406										
				18	9						With	0.5	EC11K0924404	10							
				30	15								EC11K1524406								
				18	9								EC11K0925416								
				30	15								EC11K1525413								
				18	9																
30	15																				

### Note

Other varieties are also available. Please inquire.

Refer to P.282 for product specifications.  
 Refer to P.283 for attached parts.  
 Refer to P.285 for product varieties.  
 Refer to P.315 for soldering conditions.

## ■ Product Line

Structure	Shaft configuration	Length of the shaft (mm)	Torque (mN·m)	Number of detent	Number of pulse	Push-on switch	Travel of push-on switch (mm)	Operating life (cycles)	Minimum order unit (pcs.)		Product No.	Drawing No.
									Japan	Export		
Reflow	Flat	20	12±5 (Initial) 10±4 (After reflow)	30	15	Without	—	100,000	600	600	EC11J0920404	11
											EC11J152040F	
						With	0.5				EC11J0924411	12
											EC11J1524413	
											EC11J0925403	
											EC11J1525402	
Push lock	20-tooth Serrated	25	10±7	30	15	Without	—	15,000	800	1,600	EC11E152T409	13
		26.4				With	8				EC11E152U402	14
Self-return switch	Flat	15	3 to 30	Without	Self-return switch	Without	—	15,000	1,200	2,400	EC1110120005	15
		20					0.5				EC111012010H	16
						1.5	EC1110120201					
Dual-shaft	Slotted	Inner-shaft=25	10±7	30	15	Without	—	15,000	700	1,400	EC11EBB24C03	17
		Outer-shaft=15					With				1.5	EC11E0B2LB01
	Flat	Inner-shaft=25	Without	—								
	Slotted	Outer-shaft=15	3 to 30	Without	Self-return switch	Without	—					

## ■ Note

Other varieties are also available. Please inquire.

## ■ Packing Specifications

## Tray







Product No.	Number of packages (pcs.)		Export package measurements (mm)
	1 case / Japan	1 case / export packing	
EC11B	700	1,400	370×520×201
EC11E09 / 15 / 18	1,200	2,400	540×360×250
EC11G / EC11K	1,000	2,000	
EC11J	600	600	369×283×263
EC11E152T / U	800	1,600	363×507×230
EC111	1,200	2,400	363×507×216
EC11E0B / BB	700	1,400	

Refer to P.282 for product specifications.  
 Refer to P.283 for attached parts.  
 Refer to P.285 for product varieties.  
 Refer to P.315 for soldering conditions.

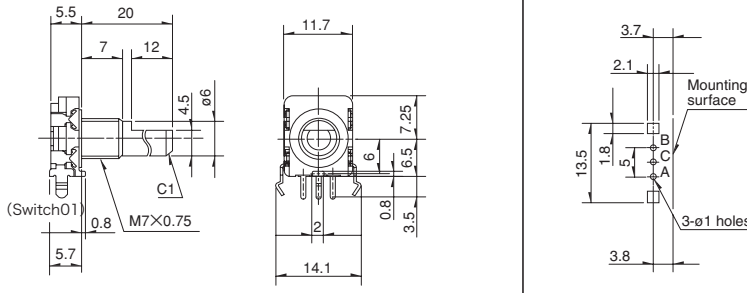
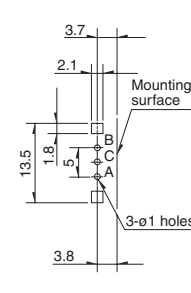
# EC11 1.1 mm Size Metal Shaft Type

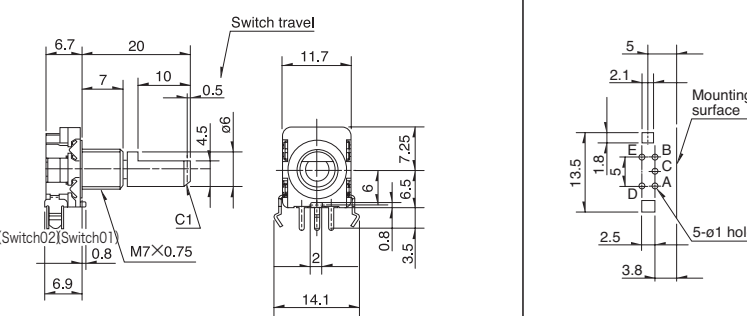
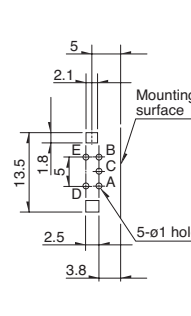
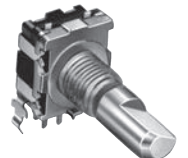
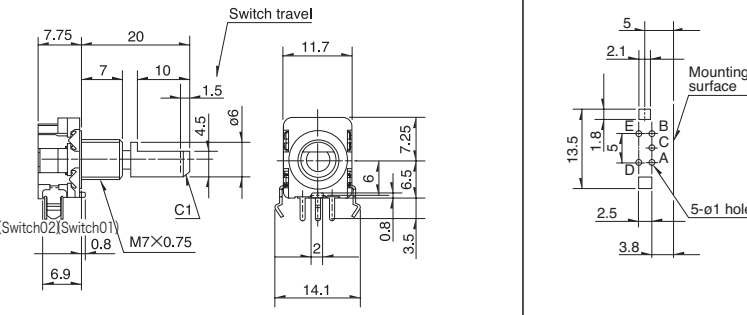
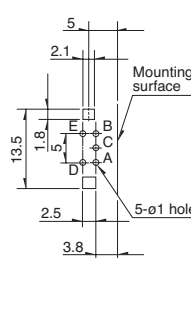
## Dimensions

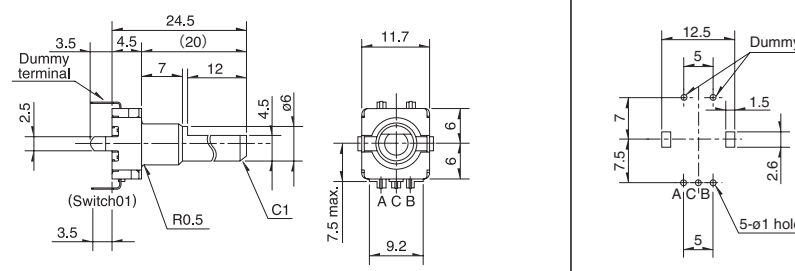
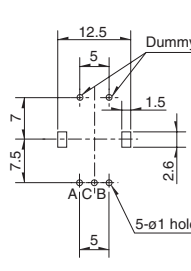
Unit:mm

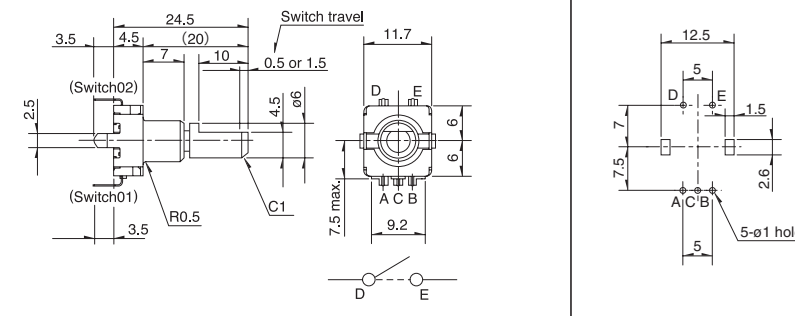
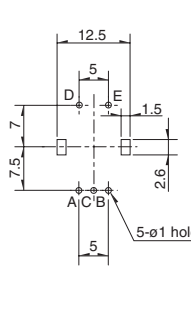
No.	Photo	Style	PC board mounting hole dimensions (Viewed from mounting side)
1			
2			
3			
4			
5			

Encoders

Metal Shaft







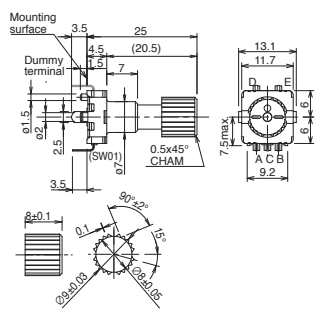
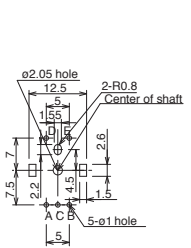

Insulated Shaft

Hollow Shaft

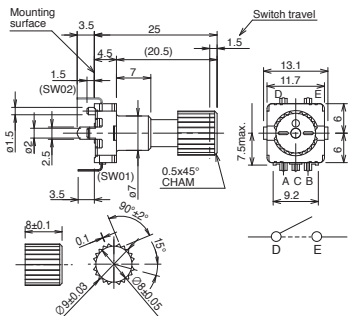
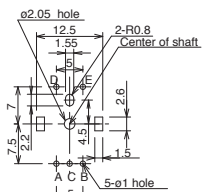
Ring Type

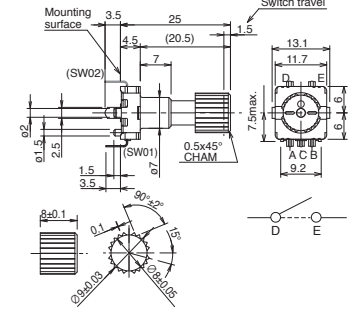
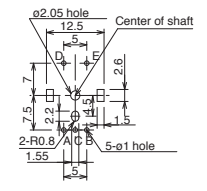
Dimensions

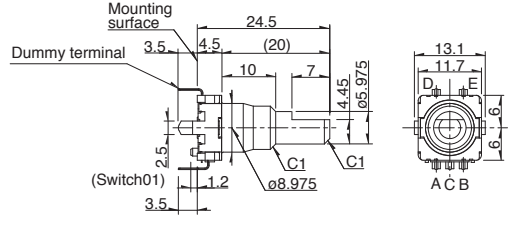
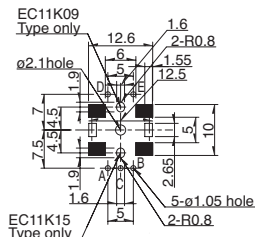
Unit:mm

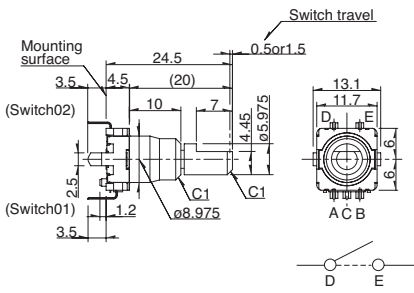
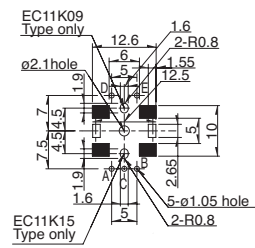





No.	Photo	Style	PC board mounting hole dimensions (Viewed from mounting side)
6	<p><b>EC11G Vertical</b></p> 		
7	<p><b>EC11G Vertical with push-on switch (travel 1.5mm)</b></p> 		
8	<p><b>EC11G Vertical with push-on switch (travel 1.5mm)</b></p> 		
9	<p><b>EC11K Vertical</b></p> 		 <p>EC11K09 Type only</p> <p>EC11K15 Type only</p> <p>Black part : Do not solder and no wiring for electrical contact.</p>
10	<p><b>EC11K Vertical with push-on switch (travel 0.5mm / 1.5mm)</b></p> 		 <p>EC11K09 Type only</p> <p>EC11K15 Type only</p> <p>Black part : Do not solder and no wiring for electrical contact.</p>

Encoders  
Metal Shaft  
Insulated Shaft  
Hollow Shaft  
Ring Type

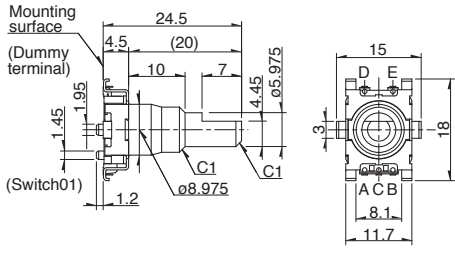
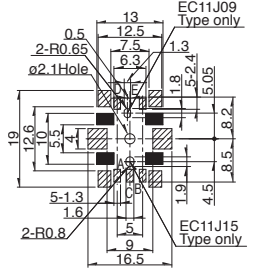
# EC11 1 mm Size Metal Shaft Type

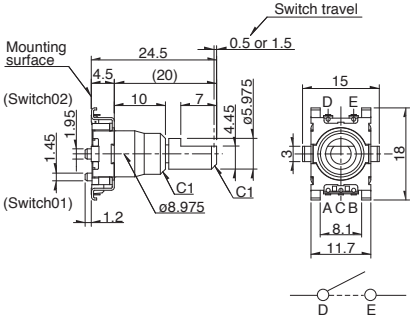
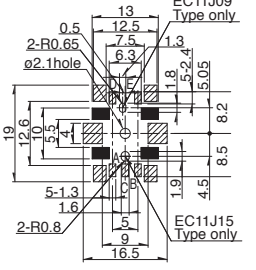
## Dimensions

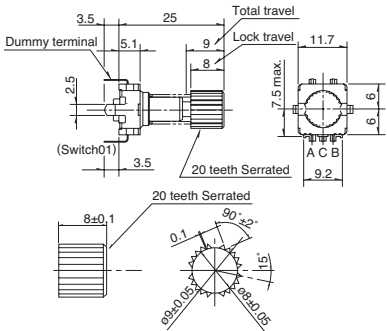
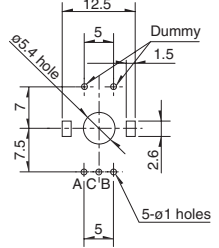
Unit:mm

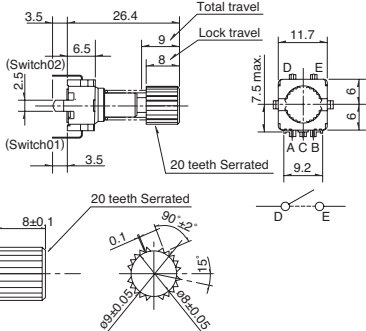
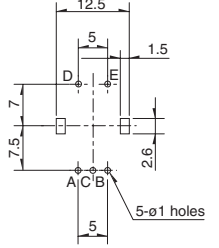
No.	Photo	Style	PC board mounting hole dimensions (Viewed from mounting side)
11			 <p>EC11J09 Type only EC11J15 Type only</p> <p>A slant line part: The solder land Black part: Do not solder and wiring for electrical contact</p>
12			 <p>EC11J09 Type only EC11J15 Type only</p> <p>A slant line part: The solder land Black part: Do not solder and wiring for electrical contact</p>
13			 <p>Dummy 5-ø1 holes</p>
14			 <p>Dummy 5-ø1 holes</p>

Encoders

Metal Shaft



Insulated Shaft

Hollow Shaft

Ring Type

■ Dimensions

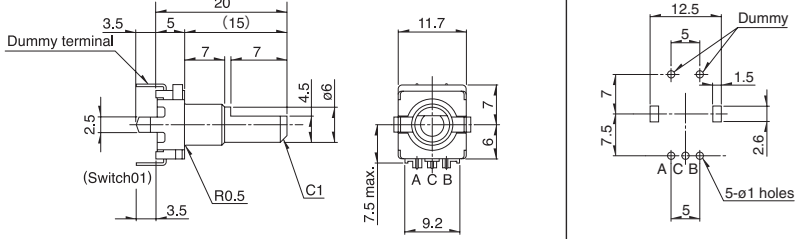
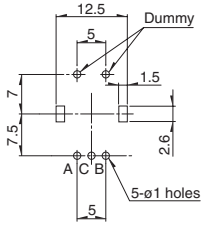
Unit:mm

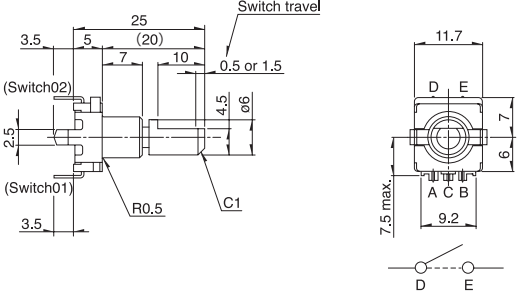
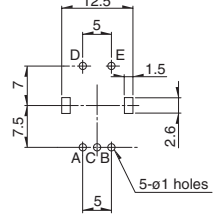
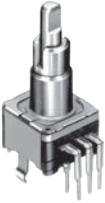
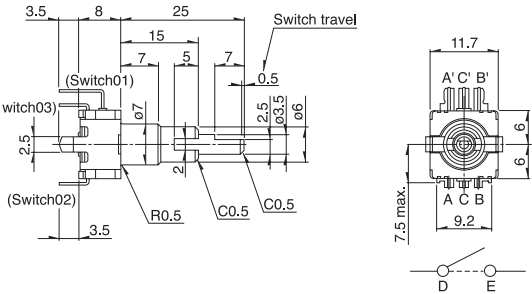
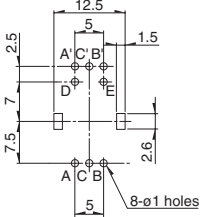
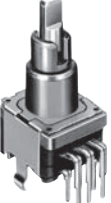
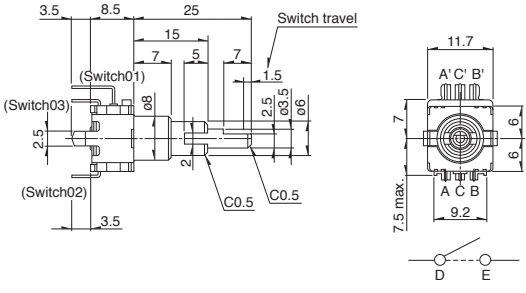
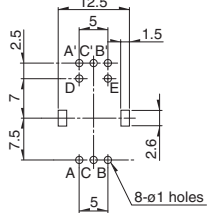
No.	Photo	Style	PC board mounting hole dimensions (Viewed from mounting side)
15	<p><b>EC111</b> <b>Self-return switch</b></p> 		
16	<p><b>EC111</b> <b>Self-return switch with push-on switch (travel 0.5mm / 1.5mm)</b></p> 		
17	<p><b>EC11E</b> <b>Dual-shaft type with push-on switch (travel 0.5mm)</b> <b>Inner shaft: encoder</b> <b>Outer shaft: encoder</b></p> 		
18	<p><b>EC11E</b> <b>Dual-shaft type with push-on switch (travel 1.5mm)</b> <b>Inner shaft: encoder</b> <b>Outer shaft: self-return switch</b></p> 		

Encoders

Metal Shaft

Insulated Shaft

Hollow Shaft

Ring Type

# EC11 11 mm Size Metal Shaft Type

Encoders

Metal Shaft

Insulated Shaft

Hollow Shaft

Ring Type

## Output Wave

EC11B / EC11E / EC11G	EC11E / EC11J / EC11K
<p>EC11B, EC11E, EC11G 30 detents, 15 pulse</p>	<p>Detent stability position cannot be specified for B signal. EC11E 18 detents 9 pulse EC11E 36 detents 18 pulse EC11J, EC11K</p>

## Sliding Noise

Measurement condition : Rotation speed 360°/s    t : Masking time to avoid chattering

<b>EC11B</b>	$V_1=V_2=1.5V$ max. At $R = 5k\Omega$ Chattering : 2ms max. Bounce : 2ms max.
<b>EC11E / EC11G</b>	$V_1=V_2=1.5V$ max. At $R = 5k\Omega$ Chattering : 3ms max. Bounce : 2ms max.
<b>EC11J / EC11K</b>	$V_1=V_2=2.5V$ max. At $R = 5k\Omega$ Chattering : 3ms max. Bounce : 2ms max.

## Circuit Diagram

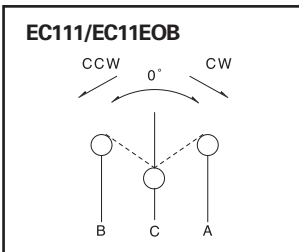

## 11 mm Size Metal Shaft Type / Attached Parts

The following parts are included with the product.

### EC11B Series

Unit:mm

Nut	Washer

# 1 1 mm Size Metal Shaft Type / Product Varieties

## ■ Shaft Dimensions

### 1. Single-shaft Type

#### 1) Serrated Type

Unit:mm

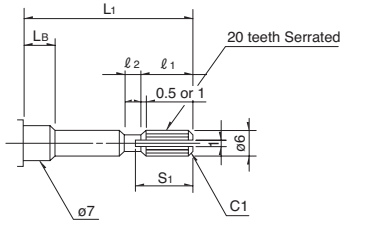
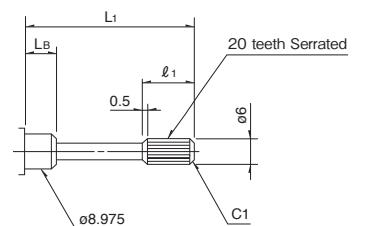
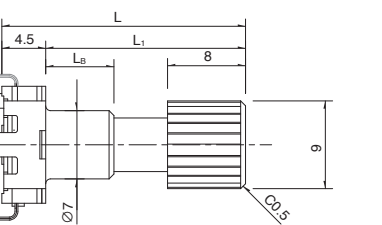
<p><b>EC11</b> Style (Shaft diameter: <math>\phi 6</math>) Not applicable for EC11E and EC11G with push-lock mechanism</p>		<p>● Detailed dimensions</p> <table border="1"> <thead> <tr> <th><math>L_1</math></th> <th><math>L_B</math></th> <th><math>l_1</math></th> <th><math>l_2</math></th> <th><math>S_1</math></th> </tr> </thead> <tbody> <tr> <td>20</td> <td>7</td> <td>6</td> <td>1</td> <td>7</td> </tr> <tr> <td>25</td> <td>10</td> <td>10</td> <td>2</td> <td>11</td> </tr> </tbody> </table>	$L_1$	$L_B$	$l_1$	$l_2$	$S_1$	20	7	6	1	7	25	10	10	2	11
$L_1$	$L_B$	$l_1$	$l_2$	$S_1$													
20	7	6	1	7													
25	10	10	2	11													
<p><b>EC11K / EC11J</b> Style (Shaft diameter: <math>\phi 6</math>)</p>		<p>● Detailed dimensions</p> <table border="1"> <thead> <tr> <th><math>L_1</math></th> <th><math>L_B</math></th> <th><math>l_1</math></th> </tr> </thead> <tbody> <tr> <td>15</td> <td>7</td> <td>5</td> </tr> <tr> <td>20</td> <td>10</td> <td>6</td> </tr> </tbody> </table>	$L_1$	$L_B$	$l_1$	15	7	5	20	10	6						
$L_1$	$L_B$	$l_1$															
15	7	5															
20	10	6															
<p><b>EC11G</b> Style (Shaft diameter: <math>\phi 9</math>)</p>		<p>● Detailed dimensions</p> <table border="1"> <thead> <tr> <th>L</th> <th><math>L_1</math></th> <th><math>L_B</math></th> </tr> </thead> <tbody> <tr> <td>18</td> <td>13.5</td> <td>5</td> </tr> <tr> <td>25</td> <td>20.5</td> <td>7</td> </tr> <tr> <td>28</td> <td>23.5</td> <td>10</td> </tr> </tbody> </table>	L	$L_1$	$L_B$	18	13.5	5	25	20.5	7	28	23.5	10			
L	$L_1$	$L_B$															
18	13.5	5															
25	20.5	7															
28	23.5	10															

#### 2) Flat Type

Unit:mm

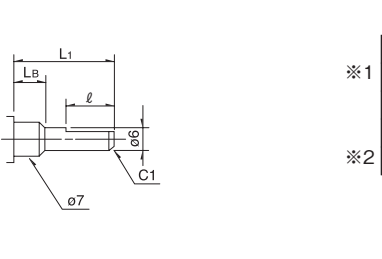
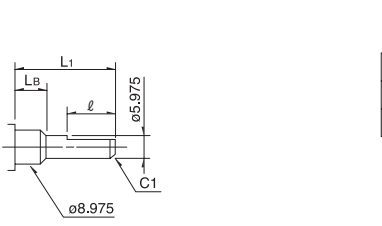
<p><b>EC11</b> Style (Shaft diameter: <math>\phi 6</math>)</p>		<p>● Detailed dimensions</p> <table border="1"> <thead> <tr> <th></th> <th><math>L_1</math></th> <th><math>L_B</math></th> <th><math>l</math></th> </tr> </thead> <tbody> <tr> <td>※1</td> <td>15</td> <td>5</td> <td>7</td> </tr> <tr> <td></td> <td>15</td> <td>7</td> <td>5 (6)</td> </tr> <tr> <td></td> <td>20</td> <td>7</td> <td>10 (12)</td> </tr> <tr> <td>※2</td> <td>25</td> <td>10</td> <td>12</td> </tr> </tbody> </table> <p>※1 Does not comply with EC111                      ※2 <math>L_B=7</math> for EC11B.                      Values in parentheses apply to products without push-on switch.</p>		$L_1$	$L_B$	$l$	※1	15	5	7		15	7	5 (6)		20	7	10 (12)	※2	25	10	12
	$L_1$	$L_B$	$l$																			
※1	15	5	7																			
	15	7	5 (6)																			
	20	7	10 (12)																			
※2	25	10	12																			
<p><b>EC11K / EC11J</b> Style (Shaft diameter: <math>\phi 5.975</math>)</p>		<p>● Detailed dimensions</p> <table border="1"> <thead> <tr> <th><math>L_1</math></th> <th><math>L_B</math></th> <th><math>l</math></th> </tr> </thead> <tbody> <tr> <td>15</td> <td>7</td> <td>5</td> </tr> <tr> <td>20</td> <td>10</td> <td>7</td> </tr> </tbody> </table>	$L_1$	$L_B$	$l$	15	7	5	20	10	7											
$L_1$	$L_B$	$l$																				
15	7	5																				
20	10	7																				

### Notes

- The highlighted figures in shaft types refer to Product Specifications in P.276 and P.277.
- Other varieties are also available. Please inquire.



# 1 1 mm Size Metal Shaft Type / Product Varieties

## Shaft Dimensions

### 1. Single-shaft Type

#### 3) Slotted Type

Unit:mm

#### EC11 Style (Shaft diameter : $\phi 6$ )

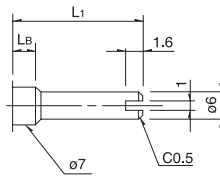

#### ● Detailed dimensions

$L_1$	$L_B$
15	7
20	7
25	10

※

※ $L_B=7$  for EC11B

#### EC11K / EC11J Style (Shaft diameter : $\phi 5.975$ )

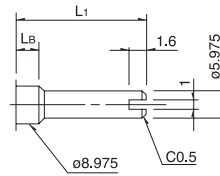

#### ● Detailed dimensions

$L_1$	$L_B$
15	7
20	10

### 2. Standard Dimensions and Configuration of Dual-shaft Type

#### Flat Type

Unit:mm

#### EC11E Style (Inner-shaft : $\phi 3.5$ Outer-shaft : $\phi 6$ )

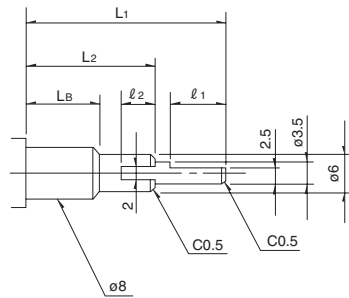

#### ● Detailed dimensions

$L_1$	$L_2$	$L_B$	$l_1$	$l_2$
20	10	5	7	4
25	15	7	7	5
30	20	10	7	5

※  $\phi 7$  for type with inner / outer shaft encoders (EC11EBB)

#### Notes

- The highlighted figures in shaft types refer to Product Specifications in P.276 and P.277.
- Other varieties are also available. Please inquire.

# 1 1 mm Size Metal Shaft Type/Switch Specifications

## 1. EC11B Series

Switch type	Momentary push switch	
Contact arrangement	Single pole and single throw (Push-on)	
Travel (mm)	$0.5^{+0.4}_{-0.3}$	$1.5 \pm 0.5$
Operating force	$6 \pm 3\text{N}$	$5 \pm 2\text{N}$
Operating life	25,000 times	20,000 times
Electrical performance	Rating	0.1A 5V DC (500 $\mu$ A 5V DC min. ratings)
	Contact resistance	100m $\Omega$ max. for initial period, 200m $\Omega$ max. after operating life.
	Insulation resistance	100M $\Omega$ min. 250V DC
	Voltage proof	300V AC for 1 minute or 360V AC for 2 second

## 2. EC11E/EC111 Series

Switch type	Momentary push switch	
Contact arrangement	Single pole and single throw (Push-on)	
Travel (mm)	$0.5 \pm 0.3$	$1.5 \pm 0.5$
Operating force	$6^{+2.5}_{-2}\text{N}$	$4 \pm 2\text{N}$
Operating life	20,000 times	
Electrical performance	Rating	0.1A 5V DC (500 $\mu$ A 5V DC min. ratings)
	Contact resistance	100m $\Omega$ max. for initial period, 200m $\Omega$ max. after operating life.
	Insulation resistance	100M $\Omega$ min. 250V DC
	Voltage proof	300V AC for 1 minute or 360V AC for 2 second

## 3. EC11G Series

Switch type	Momentary push switch	
Contact arrangement	Single pole and single throw (Push-on)	
Travel (mm)	$1.5 \pm 0.35$	
Operating force	$5 \pm 2\text{N}$	
Operating life	20,000 times	
Electrical performance	Rating	0.15A 5V DC (500 $\mu$ A 5V DC min. ratings)
	Contact resistance	100m $\Omega$ max. for initial period, 200m $\Omega$ max. after operating life.
	Insulation resistance	100M $\Omega$ min. 250V DC
	Voltage proof	300V AC for 1 minute or 360V AC for 2 second

## 4. EC11K/EC11J Series











Switch type	Momentary push switch	
Contact arrangement	Single pole and single throw (Push-on)	
Travel (mm)	$0.5 \pm 0.3$	$1.5 \pm 0.5$
Operating force	$5 \pm 2\text{N}$	$4 \pm 2\text{N}$
Operating life	1,000,000 times	100,000 times
Electrical performance	Rating	0.1A 5V DC (0.1mA 5V DC min. ratings)
	Contact resistance	100m $\Omega$ max. for initial period, 200m $\Omega$ max. after operating life.
	Insulation resistance	100M $\Omega$ min. 250V DC
	Voltage proof	300V AC for 1 minute or 360V AC for 1 second

## 5. EC11E152U Series

Switch type	Push lock mechanism switch	
Contact arrangement	Single pole and single throw (Push-on)	
Travel (mm)	$8 \pm 0.8$	
Operating force	8N max.	
Operating life	10,000 times	
Electrical performance	Rating	0.1A 5V DC (500 $\mu$ A 5V DC min. ratings)
	Contact resistance	100m $\Omega$ max. for initial period, 200m $\Omega$ max. after operating life.
	Insulation resistance	100M $\Omega$ min. 250V DC
	Voltage proof	300V AC for 1 minute or 360V AC for 2 second

# Encoders

## List of Varieties

Type		Metal shaft											
		9mm size		11mm size									
Series		EC09E		EC11B		EC11E				EC11G			
Photo													
Output		Incremental (Two phase A and B )											
Shaft types		Single-shaft						Dual-shaft		Single-shaft			
Operating direction		Vertical		Horizontal		Vertical							
Number of pulse / Number of detent		15 / 30				9 / 18 15 / 30 or without 18 / 36 or without				15 / 30 or without			
Features		—		—		Without detent Push-lock mechanism		—		Less shaft wobble			
Dimensions (mm)		W		9.5		11.7							
		D		13.75		12							
		H		4.5		5.5 / 6.7 / 7.75		4.5		8 / 8.5		4.5	
Operating temperature range		-40°C to +85°C											
Operating life		15,000 cycles											
Automotive use		●		●		●				●			
Life cycle (availability)													
Electrical performance		Rating		10mA 5V DC									
		Max./min. operating current (Resistive load)		10mA / 1mA									
		Insulation resistance		100MΩ min. 250V DC									
		Voltage proof		300V AC for 1 minute or 360V AC for 1s		300V AC for 1 minute or 360V AC for 2s							
Mechanical performance		Rotational torque (Without detent)		—		7 <sup>+3</sup> / <sub>-4</sub> mN·m		—		8.5±5mN·m			
		Detent torque		8±5mN·m		12±7mN·m		10±7mN·m		12±7mN·m			
		Push-pull strength		100N									
Shaft configuration		Flat		Flat, Slotted, Serrated				Inner-shaft : Flat Outer-shaft : Slotted		Serrated			
Terminal type		Insertion											
Switch Specifications		Switch type		Push-on switch				Push-lock mechanism switch ※		Push-on switch			
		Contact arrangement		Single pole and single throw (Push-on)									
		Travel (mm)		0.5±0.3	1.5±0.5	0.5 <sup>+0.4</sup> / <sub>-0.3</sub>	1.5±0.5	0.5±0.3	1.5±0.5	8±0.8	0.5±0.3	1.5±0.5	1.5±0.35
		Operating force (N)		6 <sup>+2.5</sup> / <sub>-2</sub>	4±2	6±3	5±2	6 <sup>+2.5</sup> / <sub>-2</sub>	4±2	8 max.	6 <sup>+2.5</sup> / <sub>-2</sub>	4±2	5±2
		Rating		10mA 5V DC (1mA 5V DC min. ratings)		0.1A 5V DC (500μA 5V DC min. ratings)							
		Contact resistance		100mΩ max. for initial period; 200mΩ max. after operating life.									
		Operating life		10,000 times		25,000 times		20,000 times		10,000 times		20,000 times	
Page		274				276							













Encoders Soldering Conditions	315
Encoders Cautions	316

### Notes

- ※marked specification is only applicable to EC11E152U402.
- Indicates applicability to all products in the series.

# Encoders

## List of Varieties

Type		Metal shaft											
		11mm size						20mm size					
Series		EC111		EC11K		EC11J		EM11B	EC20A	EM20B			
Photo													
Output		Self-return switch			Incremental (Two phase A and B)								
Shaft types		Single-shaft											
Operating direction		Vertical											
Number of pulse / Number of detent		—		9/18 15/30			16/16		18/18	40/40			
Features		—		—		Surface Mount type		Magnetic type	—	Magnetic type			
Dimensions (mm)		W		11.7						10.8	20.2	20	
		D		13		12		14.2		11	19.2	22.25	
		H		5		4.5			7.5		10	13	
Operating temperature range		-40°C to +85°C						-30°C to +85°C	-30°C to +80°C	-10°C to +70°C			
Operating life		15,000 cycles		100,000 cycles			1,000,000 cycles		30,000 cycles	500,000 cycles			
Automotive use		●		●		●		●	●	—			
Life cycle (availability)													
Electrical performance		Rating		10mA 5V DC				10mA 5V±5% DC	1mA 5V DC	10mA 5V±5% DC			
		Max./min. operating current (Resistive load)		10mA / 1mA				15mA / —		—	15mA / —		
		Insulation resistance		100MΩ min. 250V DC						100MΩ min.100V DC	10MΩ min. 50V DC	100MΩ min. 250V DC	
		Voltage proof		300V AC for 1 minute or 360V AC for 2s		300V AC for 1 minute or 360V AC for 1s			250V AC for 1 minute or 300V AC for 2s	50V AC for 1 minute or 60V AC for 2s	300V AC for 1 minute or 360V AC for 2s		
Mechanical performance		Rotational torque (Without detent)		3 to 30mN·m		—		—	—	7mN·m max.			
		Detent torque		—		12±5mN·m		12±5mN·m (Initial) 10±4mN·m (After reflow)		10±5mN·m	40±20mN·m	8±5mN·m	
		Push-pull strength		100N									
Shaft configuration		Flat, Slotted, Serrated						Flat					
Terminal type		Insertion				Reflow		Insertion					
Switch Specifications		Switch type		Push-on switch									
		Contact arrangement		Single pole and single throw (Push-on)									
		Travel (mm)		0.5±0.3		1.5±0.5		0.5±0.3		1.5±0.5	0.5 ± <sub>0.2</sub> <sup>0.3</sup>	1.5±0.5	0.5 ± <sub>0.3</sub> <sup>0.4</sup>
		Operating force (N)		6 ± <sub>2</sub> <sup>25</sup>		4±2		5±2		4±2	5±2	4±2	6±3
		Rating		0.1A 5V DC (500μA 5V DC min. ratings)		0.1A 5V DC (0.1mA 5V DC min. ratings)			5mA 5V DC (50mA 12V DC max. ratings)	0.5A 16V DC (1mA 16V DC min. ratings)	3A 16V DC (10mA 16V DC min. ratings)		
		Contact resistance		100mΩ max. for initial period, 200mΩ max. after operating life.						500mΩ max. for initial period, 5mΩ max. after operating life.	100mΩ max. for initial period, 200mΩ max. after operating life.		
		Operating life		20,000 times		1,000,000 times	100,000 times	1,000,000 times	100,000 times	1,000,000 times	20,000 times	25,000 times	
Page		276						286	288	291			

Encoders Soldering Conditions	315
Encoders Cautions	316

### Note

- Indicates applicability to all products in the series.

## Reference for Manual Soldering

Series	Tip temperature	Soldering time	No. of solders
EC05E, EC09E, EC10E, EC111, EC11B, EC11E, EC11G, EC11K, EC12D, EC12E, EC18A, EC21A, EC28A, EC35A, EC35AH, EC35B, EC40A, EC45A, EC50A, EC60B, EM11B, EM20B, EC21C, EC28C, EC35CH	350°C max.	3s max.	1 time
EC11J	350±10°C	3 <sup>+1</sup> <sub>0</sub> s	2 times

## Reference for Dip Soldering

Series	Preheating		Dip soldering		No. of solders
	Soldering surface temperature	Heating time	Soldering temperature	Soldering time	
EC09E, EC11B, EC111, EC11E, EC11G, EC11K, EC18A, EC21A, EC28A, EC35A, EC35AH, EC35B, EC50A, EC60B	100°C max.	2 min. max.	260±5°C	5±1s	2 times max.
EC10E, EC12D, EC12E, EM11B	100°C max.	1 min. max.	260±5°C	3±1s	2 times max.
EC40A	110°C max.	1 min. max.	260°C max.	10s max.	1 time
EC45A	100°C max.	2 min. max.	260°C max.	5s max.	2 times max.
EM20B	80°C max.	1 min. max.	260°C max.	3s max.	2 times max.

## Example of Reflow Soldering Condition

Temperature profile

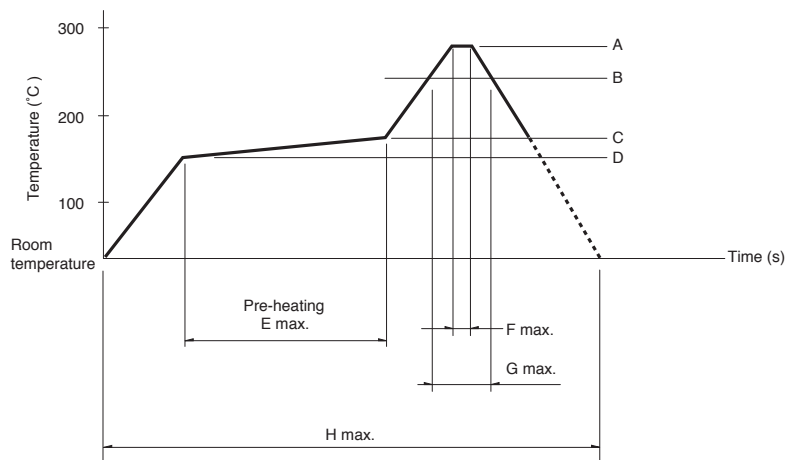

Series	A	B	C	D	E	F	G	H	No. of reflows
EC11J	260°C	230°C	180°C	150°C	2 min. max.	3s	40s	4 min. max.	2 times max.
EC05E	250°C min.	230°C min.	180°C	150°C	60s to 120s	—	30s to 40s	—	2 times max.
EC21C	230°C to 245°C	220°C	200°C	150°C	60s to 120s	—	25s to 60s	300s max.	1 time max.
EC28C, EC35CH	260°C	230°C	180°C	150°C	2 min. min.	3s	40s	230s max.	1 time max.

### 注記

1. When using an infrared reflow oven, solder may sometimes not be applied. Be sure to use a hot air reflow oven or a type that uses infrared rays in combination with hot air.
2. The temperatures given above are the maximum temperatures at the terminals of the encoder when employing a hot air reflow method. The temperature of the PC board and the surface temperature of the encoder may vary greatly depending on the PC board material, its size and thickness. Ensure that the surface temperature of the encoder does not rise to 250°C or greater.
3. Conditions vary to some extent depending on the type of reflow bath used. Be sure to give due consideration to this prior to use.